

X501-1

CLASS D MONO POWER AMPLIFIER
INSTRUCTION MANUAL
 高性能D类数字功率放大器
使用说明书

JVC KENWOOD Corporation

Safety precautions

▲ WARNING

To prevent injury or fire, take the following precautions:

- Mounting and wiring this product requires skills and experience. For safety's sake, leave the mounting and wiring work to professionals.
- When extending the ignition, battery, or ground wires, make sure to use automotive-grade wires or other wires with the range of 5 mm² (AWG 10) or more to prevent wire deterioration and damage to the wire coating.
- To prevent a short circuit, never put or leave any metallic objects (such as coins or metal tools) inside the unit.
- If the unit starts to emit smoke or strange smells, turn off the power immediately and consult your Kenwood dealer.
- Do not touch the unit during use because the surface of the unit becomes hot and may cause burns if touched.

▲ CAUTION

To prevent damage to the machine, take the following precautions:

- Be sure the unit is connected to a 12V DC power supply with a negative ground connection.
- Do not open the top or bottom covers of the unit.
- Do not install the unit in a spot exposed to direct sunlight or excessive heat or humidity. Also avoid places with too much dust or the possibility of water splashing.
- When replacing a fuse, only use a new one with the prescribed rating. Using a fuse with the wrong rating may cause your unit to malfunction.
- To prevent a short circuit when replacing a fuse, first disconnect the wiring harness.

NOTE

- If you experience problems during installation, consult your Kenwood dealer.
- If the unit does not seem to be working right, consult your Kenwood dealer.

Cleaning the unit

If the front panel gets dirty, turn off the power and wipe the panel with a dry silicon cloth or soft cloth.

▲ CAUTION

Do not wipe the panel with a hard cloth or a cloth dampened by volatile solvents such as paint thinner and alcohol. They can scratch the surface of the panel and/or cause the indicator letters to peel off.

To prevent battery rise

When the unit is used in the ACC ON position without turning the engine ON, it depletes the battery. Use it after starting the engine.

Protection function

The protection function is activated in the following situations:

- This unit is equipped with a protection function for protecting this unit and your speakers from various accidents or problems that can occur.
- When the protection function is triggered, the power indicator goes off and the amplifier stops operating.
- When a speaker wire may be short-circuited.
- When a speaker output contacts ground.
- When the unit malfunctions and a DC signal is sent to the speaker output.
- When the internal temperature is high and unit won't operate.

■ Wiring

- Take the battery wire for this unit directly from the battery. If it's connected to the vehicle's wiring harness, it can cause blown fuses etc.
- If a buzzing noise is heard from the speakers when the engine is running, connect a line noise filter (optional) to each of the battery wire.
- Do not allow the wire to directly contact the edge of the iron plate by using Grommets.
- Connect the ground wire to a metal part of the car chassis that acts as an electrical ground passing electricity to the battery's negative ⊖ terminal. Do not turn the power on if the ground wire is not connected.
- Be sure to install a protective fuse in the power cord near the battery. The protective fuse should be the same capacity as the unit's fuse capacity or somewhat larger.
- For the power cord and ground, use a vehicle type (fireproof) power wiring cord. (Use a power wiring cord with the range of 5 mm² (AWG 10) or more.)
- When more than one power amplifier are going to be used, use a power supply wiring wire and protective fuse of greater current-handling capacity than the total maximum current drawn by each amplifier.

■ Speaker selection

- Using speakers with smaller input ratings than the amplifier's output power would result in smoke generation or equipment failure.
- Use speakers that have an impedance of 2Ω or greater. When more than one set of speakers are going to be used, calculate the combined impedance of the speakers and then connect suitable speakers to the amplifier.

<Example>

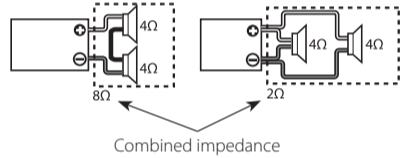

安全注意事项

▲ 警告

- 为了防止受伤和火灾，请遵守下列注意事项。
- 安装本产品 and 连接导线需要一定的技能和经验。为了保证安全，应请专业人员完成安装和连接导线作业。
- 当延长蓄电池导线和接地导线时，请使用车辆用导线或 5mm² (AWG 10) 以上的导线，以防止导线劣化和被覆面的损伤。
- 为了防止短路等事故，请勿将金属物品（硬币、工具等）掉落在装置中。
- 万一装置冒烟或有异味时，请立即关闭电源，并与建伍经销商洽谈。
- 在使用中请尽量不要接触装置表面，因为装置在使用中表面发热会烫伤人体。

▲ 注意

- 为了防止装置发生故障，请遵守下列注意事项，正确操作和使用。
- 请以负接地线的12V直流电源向本装置供电。
- 请勿打开顶部和底部的盖子。
- 请勿将本装置安装在曝露于直射阳光、高温或高湿、水可能飞溅的或有灰尘的地方。
- 更换保险丝时，请更换规定容量相同的保险丝，如使用不同容量的保险丝，可能会造成装置的故障。
- 更换保险丝时，为了防止短路事故，请先按下电源线束再进行更换。

注

- 安装有困难时，请与建伍经销商洽谈。
- 如果仍不能恢复正常时，请与建伍经销商洽谈。

装置的保养

如果外表污脏时，请关闭电源，使用干燥的无纺布或柔软的布匹擦拭。

▲ 注意

请勿使用硬布或涂料稀释剂、酒精等挥发性溶剂，以免损坏外表面或将所附指示字符擦掉。

防止蓄电池全部放电

当本机在ACC ON位置使用而不启动发动机时，将消耗蓄电池的电量，请在启动了发动机之后使用。

保护功能

在以下场合中保护功能被激活
 本机装有保护功能，可以保护本机以及扬声器不会受到可能发生的各种意外事故的损害。
 当保护功能被触发时，电源指示灯将熄灭，放大器也停止工作。

- 当扬声器线缆短路时。
- 当扬声器的输出接地时。
- 当本机出现误动作，有 DC (直流) 信号传送到扬声器输出端时。
- 内部高温不能动作时。

■ 接线

- 请将本机的蓄电池连接线直接与蓄电池连接，如果与汽车的配线束连接，将产生烧毁保险丝等故障。
- 如果发动机运转时从扬声器中发出噪音，可以在蓄电池的每根连线上加一个线路噪音滤波器（选配件）。
- 使用保护套，以防线缆直接接触触板的边缘。
- 将接地线连接到车架的金属部位，车架起到车辆电气接地的作用，将电流传递到蓄电池的负极⊖。如果接地线没有连接就不要打开电源开关。
- 务必必在蓄电池附近的电源连接线上设置保险丝。保险丝的规格应该与本机的保险丝容量相同或者略大。
- 对于电源连接线和接地线，请使用汽车用（防火）电源连接线。（请使用截面积为5mm² (AWG 10) 或者以上的电源连接线。）
- 当使用多个功率放大器时，电源导线的电流容量及保险丝的容量要大于各个放大器的使用电流之和的最大值。

■ 扬声器选择

- 使用输入额定值比放大器输出功率小的扬声器将会导致冒烟或设备故障。
- 使用的扬声器的阻抗必须大于或等于 ⊖ 欧姆。当使用一组扬声器时，必须在计算扬声器的总阻抗之后，再连接合适的扬声器。

<例>

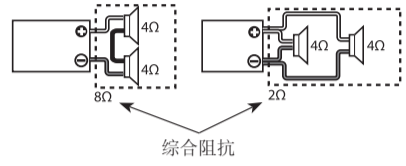

Installation / 安装

■ Accessories / 附件

①		Self-tapping screws / 自攻螺钉	4
②		Hexagon wrench / 六角扳手	1

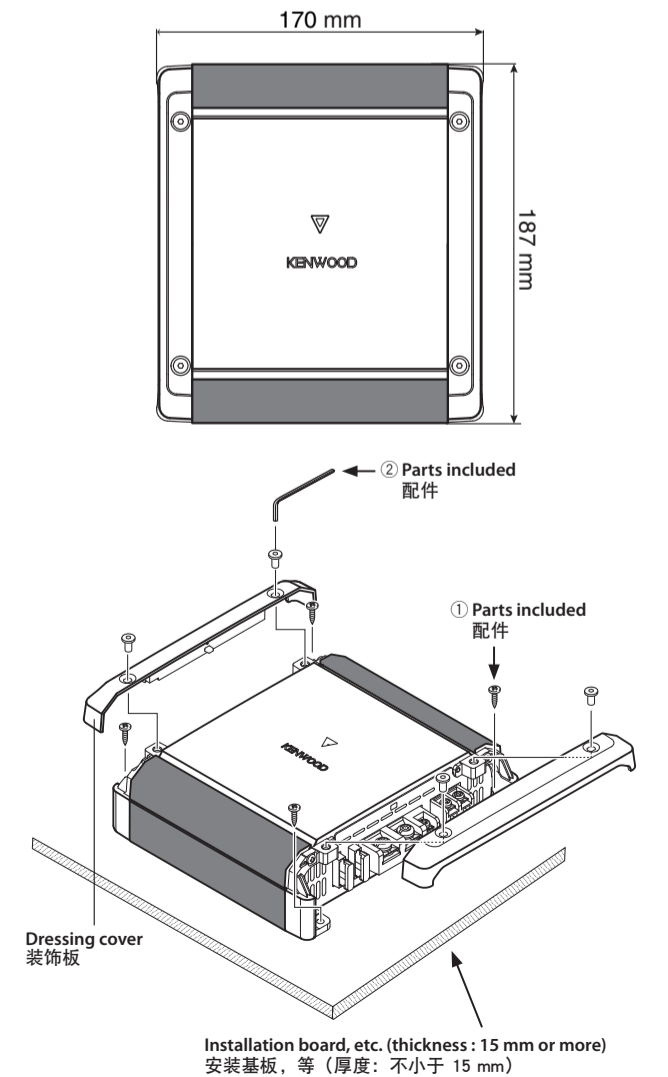

■ Installation procedure

Since there are large variety of settings and connections possible according to applications, read the instruction manual well to select the proper setting and connection.

- Remove the ignition key and disconnect the negative ⊖ terminal of the battery to prevent short circuits.
- Set the unit according to the intended usage.
- Remove the Dressing cover.
- Connect the input and output wires of the units.
- Connect the speaker wires.
- Connect the power wire, power control wire and grounding wire following this order.
- Install the installation fittings in the unit.
- Attach the unit.
- Attach the Dressing cover.
- Connect the negative ⊖ terminal of the battery.

▲ CAUTION

- Do not install in the below locations; (Unstable location, In a location that interferes with driving, In a location that gets wet, In a dusty location, In a place that gets hot, In a place that gets direct sunlight, In a location that gets hit by hot air)
- Do not install the unit under the carpet. Otherwise heat build-up occurs and the unit may be damaged.
- Install this unit in a location which allows heat to easily dissipate. Once installed, do not place any object on top of the unit.
- The surface temperature of the amplifier will become hot during use. Install the amplifier in a place where people, resins, and other substances that are sensitive to heat will not come into contact with it.
- When making a hole under a seat, inside the trunk, or somewhere else in the vehicle, check that there is nothing hazardous on the opposite side such as a gasoline tank, brake pipe, or wiring harness, and be careful not to cause scratches or other damage.
- Do not install near the dashboard, rear tray, or air bag safety parts.
- The installation to the vehicle should securely fasten the unit to a place in which it will not obstruct driving. If the unit comes off due to a shock and hits a person or safety part, it may cause injury or an accident.
- After installing the unit, check to make sure that electrical equipment such as the brake lamps, turn signal lamps and windshield wipers operate normally.

■ 安装步骤

根据使用场合的不同，可能有多种不同的连接及设定方式请务必仔细阅读使用说明书，选择适当的连接和设定。

- 拔取点火钥匙，拆掉蓄电池负极⊖端子，以防短路。
- 根据使用目的，设置本机到妥当位置。
- 去掉装饰板。
- 连接本机的输入和输出线缆。
- 连接扬声器线缆。
- 连接电源线，电源控制线缆及地线，不可违反此顺序。
- 向本机安装配件部件。
- 安装本机。
- 装上装饰板。
- 连接蓄电池的负极⊖。

▲ 注意

- 不得在下列位置安装：（不稳定的位置，妨碍驾驶车辆的位置，潮湿的位置，灰尘较多的位置，受热的位置，阳光直射的位置，热气接触的位置）
- 不可将本装置安装在绒毯底下，否则，蓄热会导致本装置损坏。
- 将本装置安装在热量容易发散的地点。一旦安装完毕，不可在其上放置其它物品。
- 机器使用过程中，机体会发生升温，所以其安装地点应该是人体、树脂及其它热敏感物质不易触及的地方。
- 在车座，行李箱底部或车子其它部位打孔时，应确认其背面有没有会受到损坏的物件，诸如油箱，刹车用配管或线路管套等，千万不可擦伤或损坏这些物品。
- 不可安装在驾驶室仪表盘，尾部底板或安全气囊等部件之上。
- 将本机安装在车内时，应确保固定牢靠，且不会对驾车造成妨碍，如果因为冲击造成本机脱落且撞及人体或保险部件，就会导致伤害或事故。
- 在本装置安装之后，应该确认电气设备，比如转向灯，转向信号灯以及雨刷等操作正常。

Connection / 连接



▲ WARNING

Particular attention must be given to making good electrical contact at the amplifier-output and speaker terminals. Poor or loose connections can cause sparking or burning at the terminals because of the very high power that the amplifier can deliver.

▲ CAUTION

- If sound is not output normally, immediately turn power off and check connections.
- Be sure to turn the power off before changing the setting of any switch.
- If the fuse blows, check wires for shorts, then replace the fuse with one of the same rating.
- Check that no unconnected wires or connectors are touching the car body. Do not remove caps from unconnected wires or connectors to prevent short circuits.
- Connect the speaker wires to appropriate speaker connectors separately. Sharing the negative wire of the speaker or grounding speaker wires to the metal body of the car can cause this unit to fail.
- After installation, check that the brake lamps, turn signal lamps and windshield wipers work properly.

▲ 警告

要特别注意放大器的输出口和扬声器端子处有良好的电气接触。因为放大器要发出非常高的功率，松弛或不良的连接可能在端子处产生火花甚至燃烧。

▲ 注意

- 如果声音输出不正常，应立即关闭电源并检查连接是否正确。
- 在变更开关的设定时，必须首先切断电源。
- 当保险丝熔断后，要检查线缆是否有短路，并更换上相同规格的保险丝。
- 检查是否有尚未连接的线缆或与车体相接触的端子。未连接线缆及其端部的保护帽不可拆掉，以防短路。
- 扬声器的线缆要分别连接到各自的端子。共用扬声器的负极线缆或扬声器端子接地到汽车的金属部分，都会导致本机停止工作。
- 安装之后，请检查汽车的转向灯、方向指示灯、雨刷等是否正常工作。

▲ WARNING

Remove the ignition key and disconnect the negative ⊖ terminal of the battery to prevent short circuits.

▲ 警告

拔取点火钥匙，拆掉蓄电池负极⊖端子，以防短路。

■ Power wire and speaker wire connection

■ 电源线和扬声器线的连接

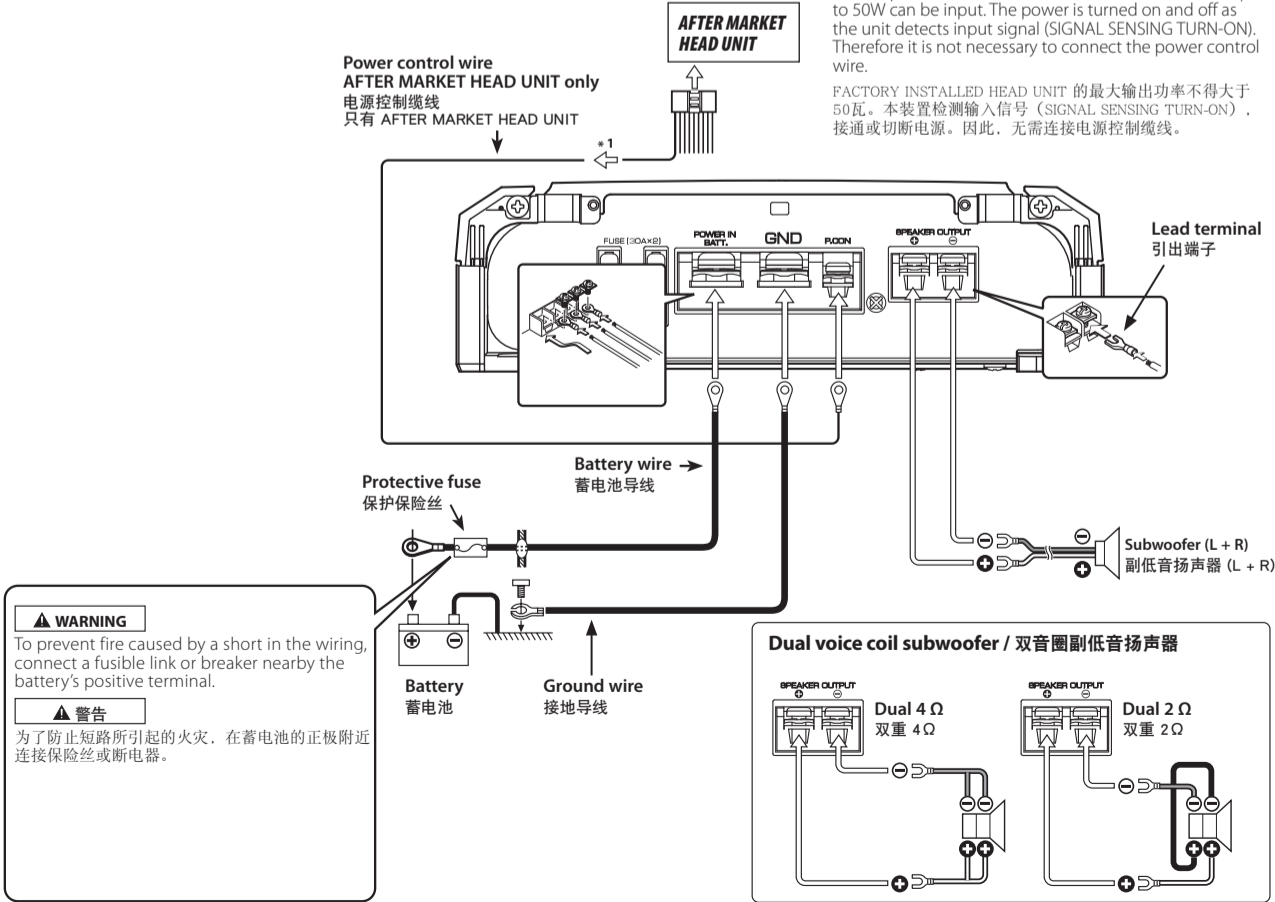

*1
 The output from the FACTORY INSTALLED HEAD UNIT up to 50W can be input. The power is turned on and off as the unit detects input signal (SIGNAL SENSING TURN-ON). Therefore it is not necessary to connect the power control wire.
 FACTORY INSTALLED HEAD UNIT 的最大输出功率不得大于 50W。本装置检测输入信号 (SIGNAL SENSING TURN-ON)，接通或切断电源，因此，无需连接电源控制线缆。

Dual voice coil subwoofer / 双音圈副低音扬声器

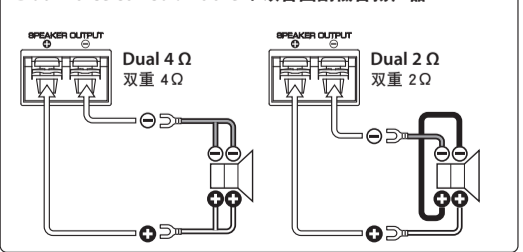

Connection / 连接

- RCA INPUT connection
- RCA INPUT 连线

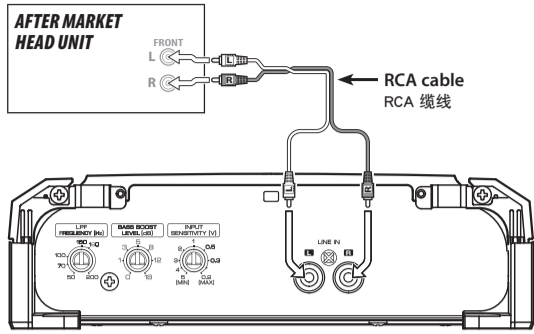

- SPEAKER INPUT connection
- SPEAKER INPUT 连线

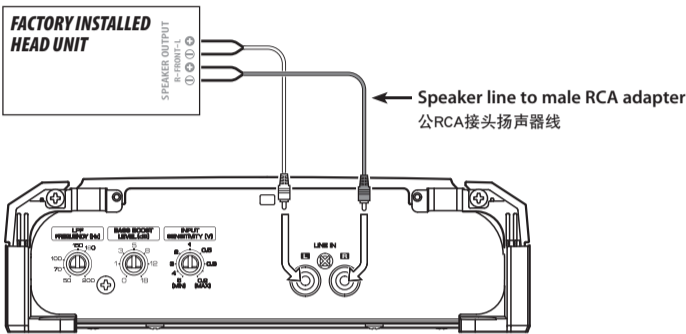

Controls / 控制

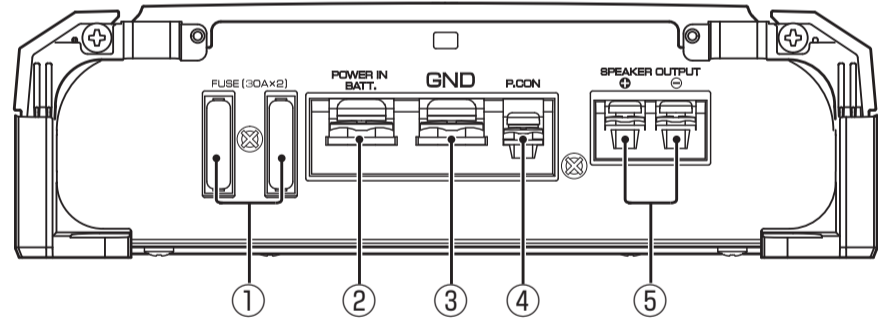

① Fuse (30 A x 2)

NOTE

If you can't find the specified capacity fuse at your store etc., consult your Kenwood dealer.

② Battery terminal (POWER IN BATT.)

③ Ground terminal (GND)

④ Power control terminal (P.CON)

Controls the unit ON/OFF.

NOTE

Controls the unit power. Be sure to connect it with all the systems.

⑤ SPEAKER OUTPUT terminals

As this unit accepts speakers with a minimum impedance of 2 ohm, connect speakers with 2-ohm or higher impedance to these terminals.

⑥ LPF FREQUENCY control

This control adjusts the frequency band output from this unit.

⑦ BASS BOOST LEVEL control

Sets the low frequency level to be compensated.

⑧ INPUT SENSITIVITY control

Set this control according to the pre-output level of the center unit connected with this unit.

NOTE

For the pre-output level, refer to the <Specifications> in the instruction manual of the center unit. The entire bandwidth is output without filtering.

⑨ LINE IN terminal

⑩ Power indicator

When the power is turned on, the Power indicator lights.

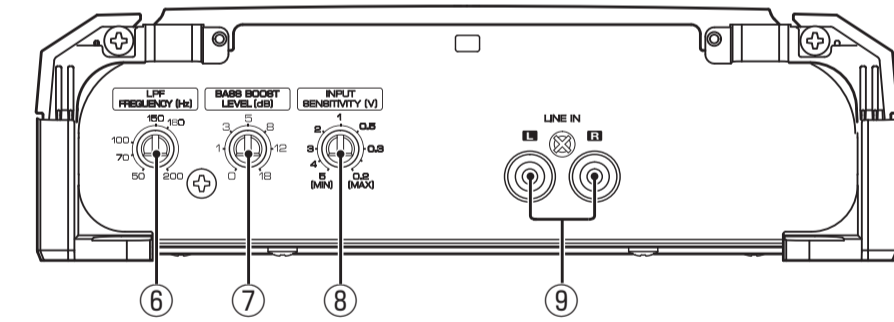

① 保险丝 (30 A x 2)

注

万一在销售店等找不到指定容量的保险丝的话,请与建伍专销公司联系。

② POWER IN BATT. (蓄电池) 端子

③ GND (接地) 端子

④ P.CON (电源控制) 端子

控制本机的接通 / 关闭。

注

控制本机电源。 请务必与全部系统连接。

⑤ SPEAKER OUTPUT (扬声器输出) 端子

本机只适用于 ≥ 欧姆以上的阻抗, 故请连接的扬声器的阻抗亦为 ≥ 欧姆以上。

⑥ LPF FREQUENCY (低通滤波频率) 控制

可以调节本机的输出频带。

⑦ BASS BOOST LEVEL (低音提升) 控制

设定进行提升的低频范围电平。

⑧ INPUT SENSITIVITY (输入灵敏度) 控制

根据与本放大器连接的中心装置的前置输出电平调节本控制钮。

注

关于中心装置的前置输出电平, 请参考其使用说明书。

⑨ LINE IN (线输入) 端子

⑩ 电源指示灯

当电源打开时, 电源指示灯点亮。

产品中有害物质的名称及含量

部件名称	有害物质					
	铅 (Pb)	汞 (Hg)	镉 (Cd)	六价铬 (Cr(VI))	多溴联苯 (PBB)	多溴二苯醚 (PBDE)
安装基板	×	○	○	×	○	○
框架	×	○	○	×	○	○
电缆类	×	○	○	×	○	○
其他 (附件)	×	○	○	×	○	○

本表格依据 SJ/T 11364 的规定编制。

○: 表示该有害物质在该部件所有均质材料中的含量均在 GB/T26572 规定的限量要求以下。

×: 表示该有害物质至少在该部件的某一均质材料中的含量超出 GB/T26572 规定的限量要求。



环保使用期限

- 此图标表示了中国《电子信息产品污染控制管理办法》规定的环保使用期限。只要用户在使用本产品时遵守注意事项中的各项规定, 从制造日期开始到此图标标出的期限为止 (环保使用期限) 既不会污染环境也不会产生对人体有害的物质。
- 附件和消耗性零件的环保使用期限如下所示: (不同产品中包含的附件和消耗性零件也不相同。)

电缆类、遥控器、麦克风、天线、蓝牙适配器: 10 年

Troubleshooting guide

What might appear to be a malfunction in your unit may just be the result of slight misoperation or miswiring. Before calling service, first check the following table for possible problems.

PROBLEM	POSSIBLE CAUSE	SOLUTION
No sound. (No sound from one side.) (Blown fuse.)	<ul style="list-style-type: none"> Input (or output) cables are disconnected. Protection circuit may be activated. Volume is too high. The speaker cord is shorted. 	<ul style="list-style-type: none"> Connect the input (or output) cables. Check connections by referring to <Protection function>. Replace the fuse and use lower volume. After check the speaker cord and fixing the cause of the short, replace the fuse.
The output level is too small (or too large).	<ul style="list-style-type: none"> The input sensitivity adjusting control is not set to the correct position. 	<ul style="list-style-type: none"> Adjust the control correctly referring to <Controls>.
The sound quality is bad. (The sound is distorted.)	<ul style="list-style-type: none"> The speakers wire are connected with wrong ⊕/⊖ polarity. A speaker wire is pinched by a screw in the car body. The switches may be set improperly. 	<ul style="list-style-type: none"> Connect them properly checking the ⊕/⊖ of the terminals and wires well. Connect the speaker wire again so that it is not pinched by anything. Set switches properly by referring to <Controls>.

故障检修

有时被认为是故障的现象, 其实是因微小的操作或配线失误而造成。 在要求维修之前, 请参照下表稍做检查为盼。

现象	原因	排除方法
没有声音 (保险丝熔断)	<ul style="list-style-type: none"> 输入 (或输出) 缆线未连接。 保护线路可能被触发。 音量过大。 扬声器电线短路。 	<ul style="list-style-type: none"> 连接输入 (或输出) 缆线。 参考 <保护功能> 一节, 检查连接状况。 请更换保险丝, 减小音量。 确认扬声器线, 解除短路原因后, 更换保险丝。
输出电平过低 (或过高)	<ul style="list-style-type: none"> 输入灵敏度调节不当, 没有位于适当位置。 	<ul style="list-style-type: none"> 调节该控制器, 请参考 <控制>。
声音质量很差 (声音失真)	<ul style="list-style-type: none"> 扬声器缆线的极性 ⊕/⊖ 连接错误。 扬声器缆线的一根被车体螺钉压迫。 开关的设定可能不妥。 	<ul style="list-style-type: none"> 请将缆线的极性 ⊕/⊖ 连接正确。 重新连接缆线, 使之不再受螺钉压迫。 请参考 <控制>, 将开关正确设置。

Specifications

Specifications subject to change without notice.

Audio section	General
Rated power output (+B = 14.4V)	Operating voltage..... 14.4 V (11 - 16 V allowable)
(4 Ω) (20 Hz - 200 Hz, ≤ 0.5 % THD)..... 300 W x 1	Current consumption..... 34 A
(2 Ω) (100 Hz ≤ 0.5 % THD)..... 500 W x 1	Dimensions (W x H x D)..... 170 x 55 x 187 mm
Speaker impedance..... 4 Ω (2 Ω to 8 Ω allowable)	Weight..... 1.3 kg
Frequency response (+0, -3 dB)..... 20 Hz - 200 Hz	
Input sensitivity (RCA)..... 0.2 V - 5.0 V	
Signal to noise ratio..... 100 dB	
Input impedance..... 10 kΩ	
Low pass filter frequency (-24 dB/oct.)..... 50 Hz - 200 Hz (variable)	
Bass Boost Control (40 Hz)..... 0 - +18 dB (variable)	

规格

规格可能会变更, 恕不另行通知。

音频部	共同
额定输出功率 (+B = 14.4V)	使用电压..... 14.4 V (允许 11 - 16 V)
(4 Ω) (20 Hz - 200 Hz, ≤ 0.5 % THD)..... 300 W x 1	消耗电流..... 34 A
(2 Ω) (100 Hz, ≤ 0.5 % THD)..... 500 W x 1	安装尺寸 (宽 x 高 x 深)..... 170 x 55 x 187 mm
扬声器阻抗..... 4 Ω (2 Ω - 8 Ω 允许)	重量..... 1.3 kg
频率响应 (+0, -3 dB)..... 20 Hz - 200 Hz	
灵敏度 (RCA)..... 0.2 V - 5.0 V	
信噪比..... 100 dB	
输入阻抗..... 10 k Ω	
低通滤波器过频率 (-24 dB/oct.)..... 50 Hz - 200 Hz (可变)	
低音增强控制 (40 Hz)..... 0 - +18 dB (可变)	