

NXR-710/ NXR-810

INSTRUCTION MANUAL

NEXEDGE

KENWOOD

JVCKENWOOD Corporation

THANK YOU!

We are grateful you purchased this **KENWOOD** repeater. We believe this easy-to-program repeater will be highly effective in your communications system, and will keep personnel operating at peak efficiency.

PRECAUTIONS

- Do not expose the unit to rain or moisture; to prevent fire or electric shock.
- Do not open the unit under any circumstances; to avoid risk of electric shock.
- Do not expose the unit to long periods of direct sunlight, nor place it close to heating appliances.
- Do not place the unit in excessively dusty and/or humid areas, nor on unstable surfaces.
- If you detect an abnormal odor or smoke coming from the unit, disconnect the power from the unit immediately. Contact your **Kenwood** service center or dealer.

NOTICES TO THE USER

- ◆ Government law prohibits the operation of unlicensed radio transmitters within the territories under government control.
- ◆ Illegal operation is punishable by fine and/or imprisonment.
- ◆ Refer service to qualified technicians only.



CAUTION

- ◆ This repeater is intended for use as a fixed base station with the antenna located outdoors on the rooftop or on an antenna tower.
- ◆ This repeater is designed for a 13.6 V DC power source! Never use a 24 V DC or higher source to power the repeater.
- ◆ Use only the supplied DC cord.
- ◆ Do not remove the ferrite core attached to the DC cord. Doing so may cause interference with radio communications.

The AMBE+2™ voice coding Technology embodied in this product is protected by intellectual property rights including patent rights, copyrights and trade secrets of Digital Voice Systems, Inc. This voice coding Technology is licensed solely for use within this Communications Equipment. The user of this Technology is explicitly prohibited from attempting to extract, remove, decompile, reverse engineer, or disassemble the Object Code, or in any other way convert the Object Code into a human-readable form. U.S. Patent Nos. #5,826,222, #5,754,974, #5,701,390, and #5,715,365.

Firmware Copyrights

The title to and ownership of copyrights for firmware embedded in **KENWOOD** product memories are reserved for JVC **KENWOOD** Corporation.

UNPACKING AND CHECKING EQUIPMENT

Note: The following unpacking information is for use by your **KENWOOD** dealer, an authorized **KENWOOD** service center, or the factory.

Carefully unpack the repeater. We recommend that you identify the items listed in the following table before discarding the packing material. If any items are missing or have been damaged during shipment, file a claim with the carrier immediately.

Item	Part Number	Quantity
Hardware fixture	J21-8559-XX	1
Front glass	B10-2635-XX	1
Name plates	B11-1259-XX	1
Cushion	G13-1801-XX	4
Cushion	G13-1802-XX	4
Foot	J02-0475-XX	2
Foot	J02-0492-XX	2
Grommet	J59-0302-XX	2
Handle	K01-0418-XX	1
Screws	N30-4006-XX	2
Screws	N35-3006-XX	5
DC cord	E30-3427-XX	1
Lead wire with connector (15 pin)	E31-3228-XX	1
Fuse	F05-1537-XX	1
Instruction Manual	B62-2201-XX	1

INSTALLATION

To install the handles onto the front panel of the repeater, align the handles with the holes on the front panel, then secure the handles using the supplied screws.

Please consult your dealer for installing the repeater and antenna.

MICROPHONE

Connect an optional KMC-30, KMC-35, KMC-27A, KMC-27B, or KMC-9C **KENWOOD** microphone to the **MIC** jack on the front panel.

CONTROLS AND FUNCTIONS

■ Front Panel

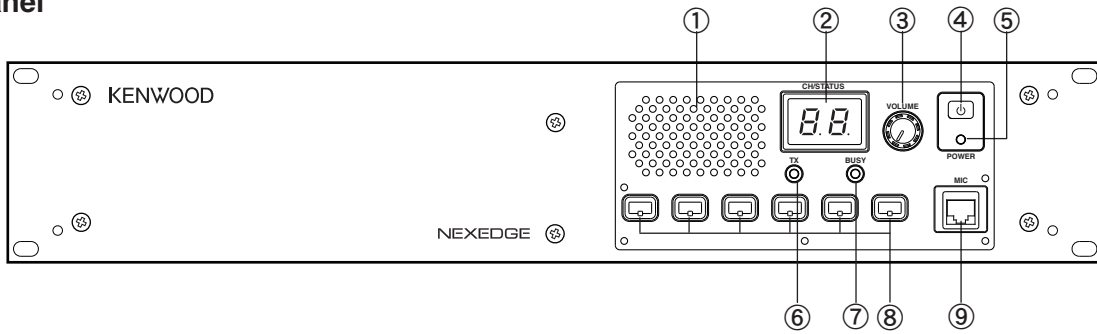

- ① **Speaker**
- ② **CH/STATUS Display**
Two 7-segment digits display the channel number, name, or status.
- ③ **VOLUME control**
Rotate to adjust the audio.
- ④ **POWER switch**
- ⑤ **POWER indicator**
Lights green when power is supplied to the **DC 13.6V** jack.
- ⑥ **MIC jack**
Connect a microphone to this 8-pin modular jack.
- ⑦ **Programmable Function keys**
Press these keys to activate their programmable functions.
- ⑧ **BUSY indicator**
Lights green while a signal is being received.
- ⑨ **TX indicator**
Lights red while transmitting.

■ Rear Panel

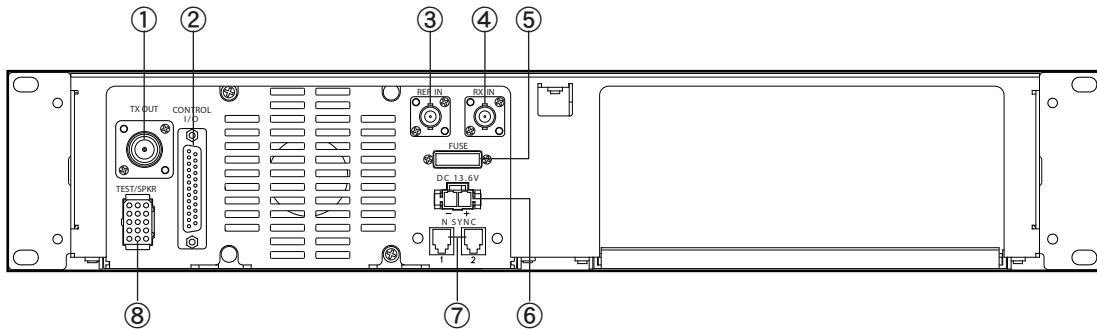

- ① **TX OUT jack**
Connect a TX antenna or a duplexer to this receptacle.
- ② **CONTROL I/O jack**
Connect a repeater controller or a remote panel to this DB-25 interface.
- ③ **REF IN jack**
Connect to a 10 MHz external oscillator.
- ④ **RX IN jack**
Connect an RX antenna or a duplexer to this BNC receptacle.
- ⑤ **FUSE**
Insert 15 A blade fuse into this fuse holder.
- ⑥ **DC 13.6V jack**
Connect a 13.6 V DC power supply to this jack.
- ⑦ **N SYNC 1 / 2 jack**
Conventional IP : Connect KTI-3 (Network Interface Unit).
Type-D Trunking : Connect each repeater with optional N-SYNC cable.
(N-SYNC cable) : E30-7701-XX (20 cm/ 0.7 ft) or E30-7717-XX (1 m/ 3.3 ft)
- ⑧ **TEST/SPKR jack**
Test input/output jack. Connect an external speaker to this jack.
When using a Built-in speaker, connect the attached Lead wire with connector (15 pin) to this jack.

REPEATER OPERATION

Note: Please consult your dealer for programming the repeater.

When power is applied to the unit, the **POWER** indicator lights:

- Green when using the DC jack.

Rotate the **VOLUME** control to adjust the audio.

The **BUSY** indicator lights green while receiving a signal and the **TX** indicator lights red while transmitting.

TRANSCEIVER OPERATION

■ Receive

Adjust the volume to your desired level. You may need to readjust the volume if you are having interference while receiving a message from your dispatcher or another member in your fleet.

The **BUSY** indicator lights green while a signal is being received.

■ Transmit

- 1 Listen to the channel before transmitting, to make sure it is not being used.
- 2 Press the microphone **PTT** switch, then speak in your normal speaking voice.
The **TX** indicator lights red while transmitting.
- 3 When you finish speaking, release the **PTT** switch.

鸣谢！

感谢您购买此 **KENWOOD** 中继台。我们坚信这一易于编程的中继台将在您的通讯系统中发挥极大作用，使您保持最高的工作效率。

事先须知

- 请勿将本机暴露于雨中或潮湿环境中，以避免着火或电击。
- 请勿在任何环境下打开本机，以避免电击的危险。
- 请勿将本机长时间地暴露在直射阳光下，或放在加热设备附近。
- 请勿将本机放在满是灰尘和 / 或潮湿的地方，或者不稳定的表面上。
- 如果发现异常气味或冒烟，请立即切断电源。并联络您的经销商或建伍服务机构。

提请用户注意

- ◆ 政府法律禁止在政府控制的区域内使用未经当局许可的无线电发射机。
- ◆ 非法使用将会受到罚款或监禁处罚。
- ◆ 只能由有资格的技术人员进行维修。

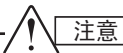

注意

- ◆ 本中继台是设计为有室外屋顶天线或天线塔天线的固定台来使用的。
- ◆ 本中继台使用 13.6 V 直流电源！
严禁使用 24 V 直流或更高的电源给中继台供电。
- ◆ 请只使用所提供的电源线。
- ◆ 请勿去掉电源上所附的铁氧体磁芯。这样做可能导致对无线电通信的干扰。

产品中有毒有害物质或元素的名称及含量

部件名称	有毒有害物质或元素					
	铅 (Pb)	汞 (Hg)	镉 (Cd)	六价铬 (Cr (VI))	多溴联苯 (PBB)	多溴二苯醚 (PBDE)
框架	○	○	○	○	○	○
安装基板	×	○	○	○	○	○
电缆	×	○	○	○	○	○
扬声器	○	○	○	○	○	○
其他(附件)	×	○	○	○	○	○

本表格依据 SJ/T 11364 的规定编制。

○：表示该有害物质在该部件所有均质材料中的含量均在 GB/T 26572 规定的限量要求以下。

×：表示该有害物质至少在该部件的某一均质材料中的含量超出 GB/T 26572 规定的限量要求。



环保使用期限

此图标表示了我国《电子信息产品污染控制管理办法》规定的环保使用期限。只要用户在使用本产品时遵守注意事项中的各项规定，从制造日期开始到此图标标出的期限为止（环保使用期限）既不会污染环境也不会产生对人体有害的物质。

附件和消耗性零件的环保使用期限如下所示：
(不同产品中包含的附件和消耗性零件也不相同。)
电缆类：10 年

固件版权

JVC 建伍株式会社保留 KENWOOD 产品存储器内嵌固件的产权和版权的所有权。

打开包装和检查设备

注意： 下列的拆箱说明仅供您的建伍经销商、授权建伍服务机构或工厂使用。

小心打开中继台的包装。建议您在丢弃包装材料之前，先验明下表中所列的物品。如果有物品缺失或在运输过程中损坏，请立即向承运人提出书面要求。

物品	部件编号	数量
硬件固定支架板	J21-8559-XX	1
前部玻璃	B10-2635-XX	1
按键功能表示贴片	B11-1259-XX	1
软垫	G13-1801-XX	4
软垫	G13-1802-XX	4
底座支脚	J02-0475-XX	2
底座支脚	J02-0492-XX	2
涨栓	J59-0302-XX	2
把手	K01-0418-XX	1
螺丝	N30-4006-XX	2
螺丝	N30-3006-XX	5
直流电源线	E30-3427-XX	1
引线连接器 (15 针)	E31-3228-XX	1
保险丝 (15 A)	F05-1537-XX	1
使用说明书	B62-2201-XX	1

安装

将把手对准前面板托架上的孔，用所提供的螺丝固定，从而将把手安装到中继台前面板上。

请向您的经销商咨询中继台和天线的安装。

麦克风

将选购的 KMC-30, KMC-35, KMC-27A, KMC-27B 或 KMC-9C 建伍麦克风连接到前面板上的麦克风插座。

本产品所包含的 AMBE +2™ 语音编码技术受 Digital Voice System, Inc. 知识产权 (包括专利权、版权和贸易机密) 的保护。

该语音编码技术仅许可用于本通信设备。该技术的使用人员明确禁止尝试提取、移除、破译、反向编译或拆除目标代码，或以其他方式将目标代码转换为人类可读形式。美国专利编号 # 5,826,222、# 5,754,974、# 5,701,390、以及 # 5,715,365。

控制和功能

■ 前面板

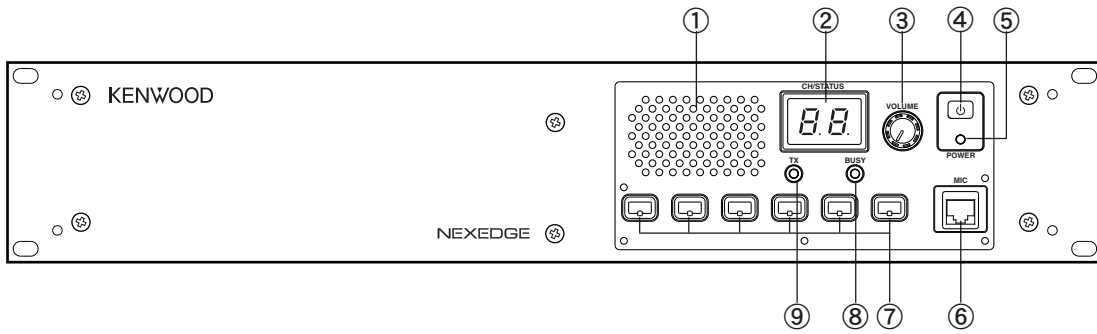

- ① 扬声器
- ② 信道 / 状态显示
两个 7 段数字显示信道号码、名称或状态。
- ③ 音量控制
顺时针转动发出咔哒一声,使音频不静音。旋转以调整音量。
逆时针转动到底来使音频静音。
- ④ 电源开关
- ⑤ 电源指示灯
当电源供给到直流 13.2V 插座时点亮绿色。当存在异常电压时闪烁红色。红色闪烁时中继台无法使用。
- ⑥ 麦克风插座
将麦克风连接到此 8- 针模块插座。
- ⑦ 可编程功能键
按这些键激活其所编程的功能。
- ⑧ 发射指示灯
发射时点亮红色。
- ⑨ 繁忙指示
正在接收信号时点亮绿色。

■ 后面板

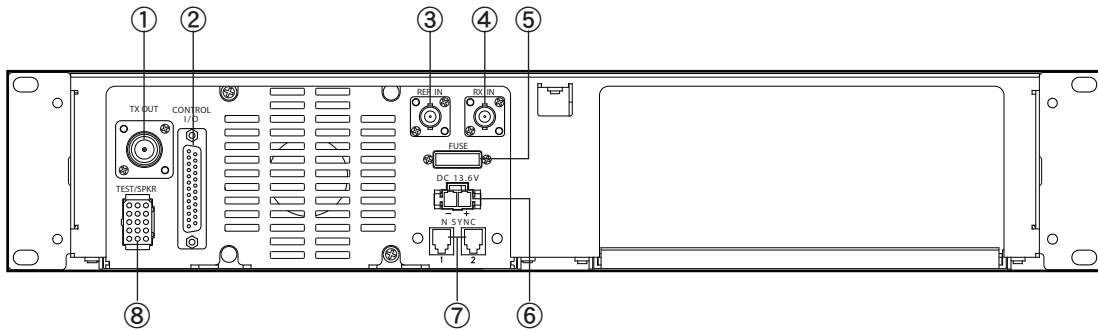

- ① TX OUT 插座
连接发射天线或双工器到此插座。
- ② CONTROL I/O 插座
连接控制器或遥控面板到此 DB25 接口。
- ③ REF IN 插座
连接到 10 MHz 外部振荡器。
- ④ RX IN 插座
连接接收天线或双工器到此 BNC 插座。
- ⑤ 保险丝
插入 15A 片状保险丝到此插座中。
- ⑥ DC 13.6V 插座
连接 13.6V 直流电源到此插座。
- ⑦ N SYNC 1/2 插座
传统 IP : 连接 KTI-3 (网络接口单元)。
D 型 Trunking : 连接每个转发器, 可选的 N-SYNC 电缆。
(N-SYNC 电缆): E30-7701-XX (20 cm) 或 E30-7717-XX (1 m)
- ⑧ TEST/SPKR 插座
测试输入 / 输出插座。连接外部扬声器到此插座。
当使用内置扬声器时, 请将附带的引线连接器 (15 针) 连接至该插孔。

中继台操作

注意:

- ◆ 请咨询您的经销商关于如何编程中继台的事宜。
- ◆ 打开电源后, 信道 / 状态显示将闪烁约 30 秒钟, 直至内部电路稳定下来。请在操作前先稍候片刻, 直至显示屏保持亮起状态。

当电源供给到本机时, 电源指示灯点亮:

- 使用 DC 插座时点亮绿色。

旋转音量控制可调整音量。

繁忙指示灯在接收信号时点亮绿色, 而发射指示灯在发射时点亮红色。

基地台操作

■ 接收

调整音量到您希望的水平。如果接收时受到干扰, 您可能需要对音量进行再度调整。

接收信号时繁忙指示灯点亮绿色。

■ 发射

- 1 发射之前先监听信道, 以保证信道没有被使用。
- 2 按下麦克风 PTT 开关, 以正常的声音讲话。
发射时发射指示灯点亮红色。
- 3 讲完话松开 PTT 开关。