

KENWOOD

KAC-X541 **KAC-PS541**

4/3/2 CHANNEL POWER AMPLIFIER

INSTRUCTION MANUAL

KENWOOD CORPORATION

Safety precautions

▲WARNING

To prevent injury or fire, take the following precautions:

- When extending the ignition, battery, or ground wires, make sure to use automotive-grade wires or other wires with a 8 mm² (AWG 8) or more to prevent wire deterioration and damage to the wire coating.
- To prevent a short circuit, never put or leave any metallic objects (such as coins or metal tools) inside the unit.
- If the unit starts to emit smoke or strange smells, turn off the power immediately and consult your Kenwood dealer.
- Do not touch the unit during use because the surface of the unit becomes hot and may cause burns if touched.

▲CAUTION

To prevent damage to the machine, take the following precautions:

- Be sure the unit is connected to a 12V DC power supply with a negative ground connection.
- Do not open the top or bottom covers of the unit.
- Do not install the unit in a spot exposed to direct sunlight or excessive heat or humidity. Also avoid places with too much dust or the possibility of water splashing.
- When replacing a fuse, only use a new one with the prescribed rating. Using a fuse with the wrong rating may cause your unit to malfunction.
- To prevent a short circuit when replacing a fuse, first disconnect the wiring harness.

Available Control Units:

A KENWOOD's LX-Bus supporting Center Unit released in 2004 or later can control this unit. The operations of the (LX) AMP Control are explained in the Operation Manual of the Center Unit.

NOTE

- The LX AMP and the sensor unit cannot be connected simultaneously. You must connect any of them at a time.

NOTE

- If you experience problems during installation, consult your Kenwood dealer.
- If the unit does not seem to be working right, consult your Kenwood dealer.

Cleaning the unit

If the front panel gets dirty, turn off the power and wipe the panel with a dry silicon cloth or soft cloth.

▲CAUTION

Do not wipe the panel with a hard cloth or a cloth dampened by volatile solvents such as paint thinner and alcohol. They can scratch the surface of the panel and/or cause the indicator letters to peel off.

To prevent battery rise

When the unit is used in the ACC ON position without turning the engine ON, it depletes the battery. Use it after starting the engine.

Protection function

There is a Protection function installed in the unit to protect the unit and speakers from various problems. When Protection operates, the display informs you of the condition.

| Display | Informations |
|----------------------------|--|
| "E-01" | When the inside of the unit is overheating. |
| "E-02" | When the unit has failed and direct current voltage is generated to the speaker's output. NOTE Turn the power OFF and release the protection. If the "E-02" code does not disappear, contact your Kenwood dealer. |
| "E-03" | When the speaker cord is shorted. When the speaker output is in contact with the vehicle ground. |
| "VOLT" display is blinked. | When voltage gets out of operation range. |

Wiring

- Take the battery wire for this unit directly from the battery. If it's connected to the vehicle's wiring harness, it can cause blown fuses etc.
- If a buzzing noise is heard from the speakers when the engine is running, connect a line noise filter (optional) to each of the battery wire.
- Do not allow the wire to directly contact the edge of the iron plate by using Grommets.
- Connect the ground wire to a metal part of the car chassis that acts as an electrical ground passing electricity to the battery's negative ⊖ terminal. Do not turn the power on if the ground wire is not connected.
- Be sure to install a protective fuse in the power cord near the battery. The protective fuse should be the same capacity as the unit's fuse capacity or somewhat larger.
- For the power cord and ground, use a vehicle type (fireproof) power wiring cord with a current capacity greater than the unit's fuse capacity. (Use a power wiring cord with a diameter of 8 mm² (AWG 8) or greater.)
- When more than one power amplifier are going to be used, use a power supply wiring wire and protective fuse of greater current-handling capacity than the total maximum current drawn by each amplifier.

Speaker Selection

- The rated input power of the speakers that are going to be connected should be greater than the maximum output power (in Watts) of the amplifier. Use of speakers having input power ratings that are less than the output power of the amplifier will cause smoke to be emitted as well as damage.
- The impedance of the speakers that are going to be connected should be 2Ω or greater (for stereo connections), or 4Ω or greater (for bridged connections). When more than one set of speakers are going to be used, calculate the combined impedance of the speakers and then connect suitable speakers to the amplifier.

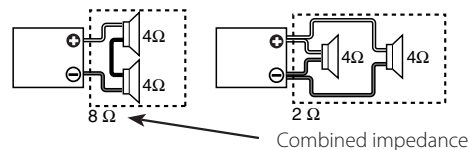

Installation

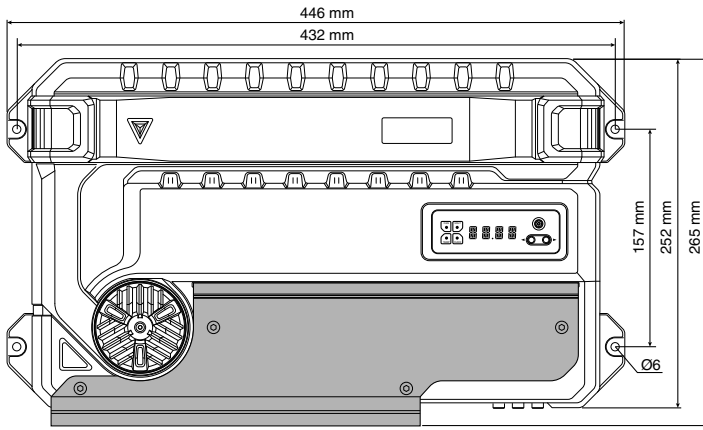

Accessories

| Part name | External View | Number of Items |
|---|---------------|-----------------|
| Self-tapping screws (ø5 × 18 mm) | | 4 |
| Hexagon socket head cap screw (M4 × 8 mm) | | 4 |
| Cover | | 1 |
| Terminal cover (Power terminal) | | 1 |
| Hexagon Wrench | | 1 |

Installation procedure

Since there are large variety of settings and connections possible according to applications, read the instruction manual well to select the proper setting and connection.

1. Remove the ignition key and disconnect the negative \ominus terminal of the battery to prevent short circuits.
2. Set the unit according to the intended usage.
3. Connect the input and output wires of the units.
4. Connect the speaker wires.
5. Connect the power wire, power control wire and grounding wire following this order.
6. Install the installation fittings in the unit.
7. Attach the unit.
8. Install the terminal cover.
9. Connect the negative \ominus terminal of the battery.

CAUTION

- Do not install in the below locations; (Unstable location, In a location that interferes with driving, In a location that gets wet, In a dusty location, In a place that gets hot, In a place that gets direct sunlight, In a location that gets hit by hot air)
- Do not install the unit under the carpet. Otherwise heat build-up occurs and the unit may be damaged.
- Install this unit in a location which allows heat to easily dissipate. Once installed, do not place any object on top of the unit.
- The surface temperature of the amplifier will become hot during use. Install the amplifier in a place where people, resins, and other substances that are sensitive to heat will not come into contact with it.
- This unit has cooling fans to decrease the internal temperature. Do not mount the unit in a place where the cooling fan and ducts of the unit are blocked. Blocking these openings will inhibit the cooling of the internal temperature and result in malfunction.
- When making a hole under a seat, inside the trunk, or somewhere else in the vehicle, check that there is nothing hazardous on the opposite side such as a gasoline tank, brake pipe, or wiring harness, and be careful not to cause scratches or other damage.
- Do not install near the dashboard, rear tray, or air bag safety parts.
- The installation to the vehicle should securely fasten the unit to a place in which it will not obstruct driving. If the unit comes off due to a shock and hits a person or safety part, it may cause injury or an accident.
- After installing the unit, check to make sure that electrical equipment such as the brake lamps, turn signal lamps and windshield wipers operate normally.

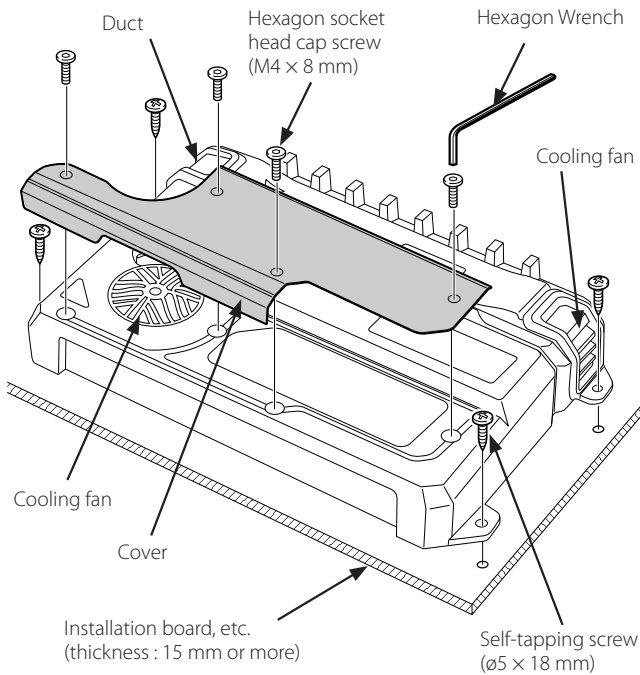

▲WARNING

To prevent fire caused by a short in the wiring, connect a fusible link or breaker nearby the battery's positive terminal.

▲CAUTION

- If sound is not output normally, immediately turn power off and check connections.
- Be sure to turn the power off before changing the setting of any switch.
- If the fuse blows, check wires for shorts, then replace the fuse with one of the same rating.
- Check that no unconnected wires or connectors are touching the car body. Do not remove caps from unconnected wires or connectors to prevent short circuits.
- Connect the speaker wires to appropriate speaker connectors separately. Sharing the negative wire of the speaker or grounding speaker wires to the metal body of the car can cause this unit to fail.
- After installation, check that the brake lamps, wipers, and wipers work properly.

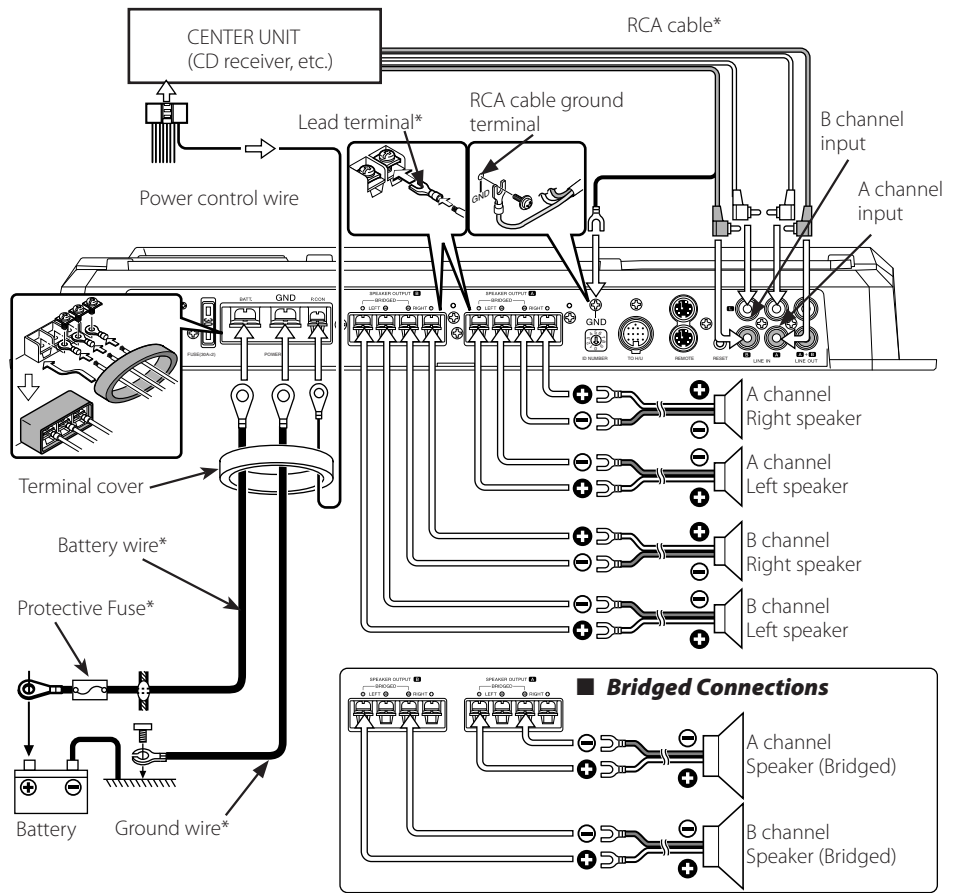

■ LX-Bus connection

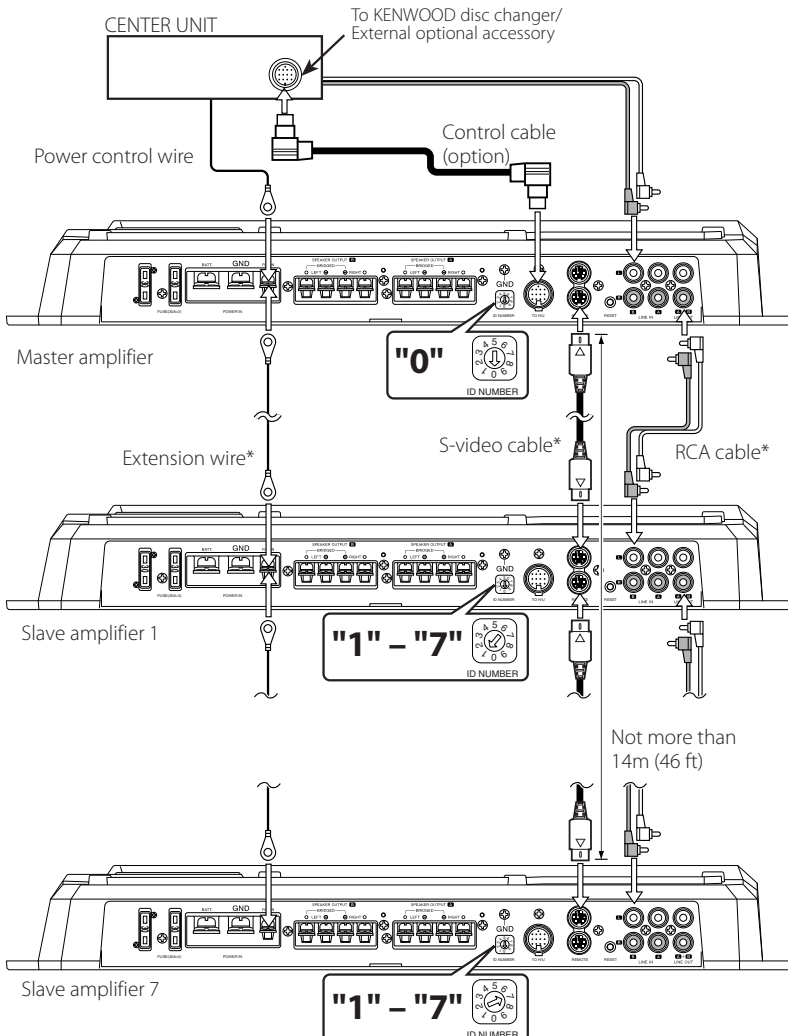

Set the ID number of the Master amplifier to "0".

You can connect up to 7 Slave amplifiers. Assign them ID numbers "1" to "7" and do not duplicate them.

▲CAUTION

- Do not connect 2 Master amplifiers to the Center Unit. If done, you cannot control all amplifiers connected to the Center Unit.
- The LX AMP and the sensor unit cannot be connected simultaneously. You must connect any of them at a time.

NOTE

- The total length of S-video cables you can connect is 14 meters (46 ft) maximum. If the cable length exceeds this limit, you cannot control amps from the Center Unit.
- If you assign the same ID number to multiple amplifiers, they malfunction when you operate any of them from the Center Unit.
- If you assign ID number "8" or "9" to a Slave amplifier, it is not recognized by the Center Unit.

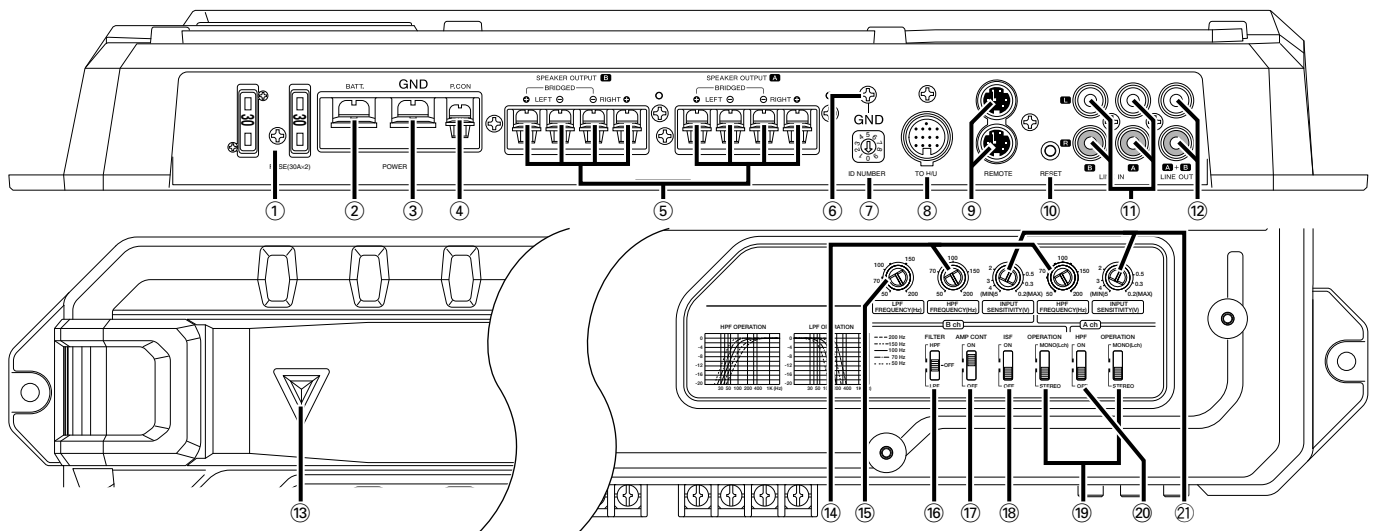

This is a 4 channel amplifier including 2 stereo amplifiers in a body. One amplifier is referred to as amplifier A and the other is amplifier B. This unit is compatible with a large variety of systems by combining the switches and functions described in the following.

① **Fuse (30 A × 2)**

② **Battery terminal**

③ **Ground terminal**

④ **Power control terminal**

Controls the unit ON/OFF.

NOTE

Controls the unit power. Be sure to connect it with all the systems.

⑤ **Speaker output terminals (A.ch/B.ch)**

• **Stereo Connections:**

When you wish to use the unit as a stereo amplifier, stereo connections are used.

The speakers to be connected should have an impedance of 2Ω or greater. When multiple speakers are to be connected, ensure that the combined impedance is 2Ω or greater for each channel.

• **Bridged Connections:**

When you wish to use the unit as a high-output monaural amplifier, bridged connections are used. (Make connections to the LEFT channel ⊕ and the RIGHT channel ⊖ SPEAKER OUTPUT terminals.)

The speakers to be connected should have an impedance of 4Ω or greater. When multiple speakers are to be connected, ensure that the combined impedance is 4Ω or greater.

CAUTION

The rated input of the speakers should be no less than the maximum output of the amplifier. Otherwise malfunction may result.

⑥ **RCA cable ground lead terminal**

When using an RCA cable with a ground lead attached, connect the ground lead to this terminal.

⑦ **ID NUMBER switch**

Sets an amp identification number (ID) to be used for amplifier control from the Center Unit.

Assign ID Number "0" to an amplifier when you use it as the Master amplifier. Assign ID Numbers "1" to "7" to amplifiers when you use them as Slave amplifiers. Do not duplicate these numbers.

NOTE

After you have changed ID numbers of amplifiers, turn Off the POWER switch of the Center Unit and turn it On again.

⑧ **TO H/U terminal**

After you have set the Master amplifier, connect it to the Center Unit.

⑨ **REMOTE terminals**

Used to connect to Slave amplifiers.

⑩ **RESET button**

Resets the microprocessor of the unit.

NOTE

The values you have set with the Amplifier Control are NOT reset.

⑪ **LINE IN terminal (A.ch/B.ch)**

⑫ **LINE OUT terminal**

These jacks output respectively the signals input to amplifiers A and B. They always output the stereo signals regardless of the position of the OPERATION switch.

⑬ **Power indicator**

Lights when the POWER switch is turned On.

The indicator flashes several seconds when the POWER switch is turned On or when the Protection function is activated.

⑭ **HPF FREQUENCY control (A.ch/B.ch)**

A: Sets the cutoff frequency when the "HPF" switch is set to "ON".

B: Sets the cutoff frequency when the "FILTER" switch is set to "HPF".

⑮ **LPF FREQUENCY control (B.ch)**

Sets the cutoff frequency when the "FILTER" switch is set to "LPF".

⑯ **FILTER switch (B.ch)**

This switch allows to apply high-pass or low-pass filtering to the speaker outputs.

• **HPF (High-Pass Filter) position:**

The filter outputs the band of higher frequencies than the frequency set with the "HPF FREQUENCY" control.

• **OFF position:**

The entire bandwidth is output without filtering.

• **LPF (Low-Pass Filter) position:**

The filter outputs the band of lower frequencies than the frequency set with the "LPF FREQUENCY" control.

The speaker output is automatically switched to monaural (L+R).

⑰ **AMP CONT (amplifier control) switch (B.ch)**

Used to bypass the circuit when you do not control the sound with the Amplifier Control.

• **ON position:**

You can control the sound of amplifier B using the Amplifier Control.

• **OFF position:**

Bypasses the Amplifier Control circuit.

NOTE

Amplifier control is possible even while OFF.

⑱ **ISF (infrasonic filter) switch (B.ch)**

When this switch is "ON", the frequencies which are below the audible range and therefore inaudible are cut off so that the quality of the audible frequencies can be improved.

⑲ **OPERATION switch (A.ch/B.ch)**

The amplification methods of the signals input to amplifiers A and B can be selected independently according to the setting of this switch.

• **STEREO position:**

The amplifier can be used as a stereo amplifier.

• **MONO (Lch) position:**

Amplifies the signal input from the left side only. Set to this position and make bridged connections to use as a high-power monaural amplifier. (The input right signal is not output.)

⑳ **HPF (High-Pass Filter) switch (A.ch)**

This switch allows to apply high-pass filtering to the speaker outputs.

• **ON position:**

The filter outputs the band of higher frequencies than the frequency set with the "HPF FREQUENCY" control.

• **OFF position:**

The entire bandwidth is output without filtering.

㉑ **INPUT SENSITIVITY control (A.ch/B.ch)**

Set this control according to the pre-output level of the center unit connected with this unit.

NOTE

For the pre-output level, refer to the "Specifications" in the instruction manual of the center unit.

Amplifier Control System

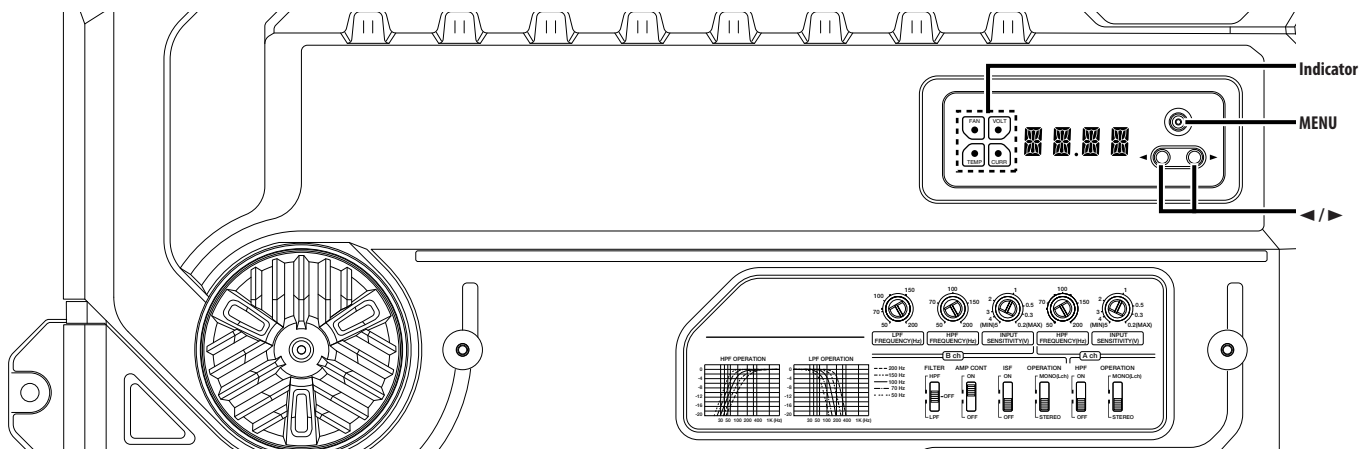

Display mode

You can set up the display items as follows:

1 Enter Menu mode

Press the [MENU] button.

"VOLT"/"CURR"/"TEMP"/"FAN" is displayed.

2 Select a display item

Press the [◀] or [▶] button.

The display items are switched in the following sequence.

| Display | Information |
|---------|--|
| "VOLT" | Indicates the source voltage (V). |
| "CURR" | Indicates the current consumption (A). |
| "TEMP" | Indicates the internal temperature (°F/°C). |
| "FAN" | Indicates the rotation speed of the cooling fan in 3 steps: "FAST", "SLOW" or "OFF". |

3 Exit Menu mode

Press the [MENU] button for at least 1 second.

NOTE

When the internal temperature is -22°F/-30°C or less, "-22F"/"-30C" is displayed.

Separate Amp Control

The following explains how to control the sound of amplifier B using the Amplifier Control of the unit.

1 Enter Menu mode

Press the [MENU] button.

2 Select the Menu item

Press the [MENU] button.

The setup items are displayed approximately 1 second first, then the set values are displayed.

3 Adjust the Menu item

Press the [◀] or [▶] button.

The setup items and set values are switched as follows.

| Display | Range | Adjustment Item |
|----------------------------|--|---|
| "VOLT"/"CURR"/"TEMP"/"FAN" | | For the operation method refer to 'Display mode' |
| "BASS" | 60/80/100/200 (Hz) | Bass Center Frequency |
| "BA G" | B-15 — B+15 (dB) | Bass level |
| "BA Q" | Q1.00/Q1.25/Q1.50/Q2.00 | Bass Q Factor |
| "EXT" | ON/OFF | When the bass extend is set to ON, low frequency response is extended by 20%. |
| "TREB" | 10/12/15/17 (kHz) | Treble Center Frequency |
| "TR G" | T-15 — T+15 (dB) | Treble level |
| "VOL" | -20 — 0 (dB) | Volume offset |
| "TEMP" | FAHR (Fahrenheit) or CELS (Centigrade) | The Fahrenheit or Centigrade temperature unit can be selected for the Display mode. |
| "DEFA" | | For the operation method refer to 'Default' |
| "AMP" | 0 — 7 | The ID Number you have assigned is displayed. |

4 Exit Menu mode

Press the [MENU] button for at least 1 second.

NOTE

When you hold down the [▶] button 3 or more seconds during ID number display ("AMP"), message "MEMO" is displayed and you can register the values you have set with the Amplifier Control. To call the Amplifier Control's values, hold down the [◀] button 3 or more seconds during ID number display ("AMP"). Then, you can recall the value when message "LOAD" is displayed.

Default

Resets all values you have set to the initial (default) values.

1 Enter Menu mode

Press the [MENU] button.

2 Select Default mode

Press the [MENU] button.

Select the "DEFA" display.

3 Resets the value to its default

Press the [▶] button for at least 2 seconds.

Message "----" is displayed, and the value is initialized.

4 Exit Menu mode

Press the [MENU] button for at least 1 second.

NOTE

Volume offset value can not be initialized.

Display Demonstration

The "VOLT"/"CURR"/"TEMP"/"FAN" items are displayed repeatedly.

Press the [MENU] button for at least 2 seconds.

The indicator flashes in the Demonstration mode.

Canceling the Demonstration mode

Press any button to cancel the Demonstration mode.

Control an Amp from Center Unit

The following explains how to control the sound of Amplifier B by operating the Amplifier Control of the unit from the Center Unit.

1 Enter AMP Control mode

Select the AMP Control mode by following the 'AMP Control' procedure given on the Operation Manual of the Center Unit.

NOTE

Use the set item and value operation buttons by following the instructions given on the Operation Manual of the Center Unit.

2 Select an amp number to operate

Operate the desired set item with the Center Unit.

Select the "AMP NO"/"AMP CONTROL NO" display.

NOTE

When the Center Unit is in the STANDBY mode, message "AMP OFF" is displayed and you cannot operate the set items.

3 Set an ID number of Amp to operate

Set an amp's ID number on the Center Unit.

You can select an ID number of "0" to "7" of connected amps.

4 Select the AMP Control item for adjustment

Select the desired set item on the Center Unit.

5 Adjust the AMP Control item

You can set a value of each item on the Center Unit.

The set items and their values are switched and displayed as follows.

| Display | Range | Adjustment Item |
|-------------------------------|-------------------------|--|
| "VOLT"/"CURR"/"TEMP"/"FAN" | | The amp state is displayed. |
| "VOLT" | | Indicates the source voltage (V). |
| "CURR" | | Indicates the current consumption (A). |
| "TEMP" | | Indicates the internal temperature (°F/°C). |
| "FAN" | | Indicates the rotation speed of the cooling fan in 3 steps: "FAST", "SLOW" or "OFF". |
| "BAS F"/"BASS FREQ" | 60/80/100/200 (Hz) | Bass Center Frequency |
| "BAS G"/"BASS GAIN" | -15 — +15 (dB) | Bass level |
| "Q FA"/"Q FACTOR" | Q1.00/Q1.25/Q1.50/Q2.00 | Bass Q Factor |
| "EXT"/"BASS EXT" | ON/OFF | When the bass extend is set to ON, low frequency response is extended by 20%. |
| "TRE F"/"TREB FREQ" | 10/12/15/17 (kHz) | Treble Center Frequency |
| "TRE G"/"TREB GAIN" | -15 — +15 (dB) | Treble level |
| "VOL"/"VOL OFFSET" | -20 — 0 (dB) | Volume offset |
| "AMP NO"/ "AMP CONTROL NO" | 0 — 7 | Select an ID number of the amp you use. |

6 Exit AMP Control mode

Releases the Amp Control mode by the Center Unit.

NOTE

When you have controlled the bass or treble of the sound using the Equalizer or DSP function of the Center Unit, and when you amplify the same frequency as that controlled by the Amplifier Control, the sound may be distorted due to an input overflow.

Messages that may be displayed on the Center Unit

When you are selecting an item with the Amp Control, an error status of the amplifier is displayed on the Center Unit.

| Display | Informations |
|--------------------------------|--|
| "AMP × E-01"/"AMP × COND E-01" | When the inside of the unit is overheating. When the unit has failed and direct current voltage is generated to the speaker's output. |
| "AMP × E-02"/"AMP × COND E-02" | NOTE Turn the POWER switch Off and release the protection. If the error message continues, consult to the KENWOOD's dealership. |
| "AMP × E-03"/"AMP × COND E-03" | When the speaker cord is shorted. When the speaker output is in contact with the vehicle ground. |
| "AMP OFF" | When you use the Amp Control in the Standby mode. |

NOTE

Number "x" on the display indicates the amp's ID number.

System examples

4-channel system

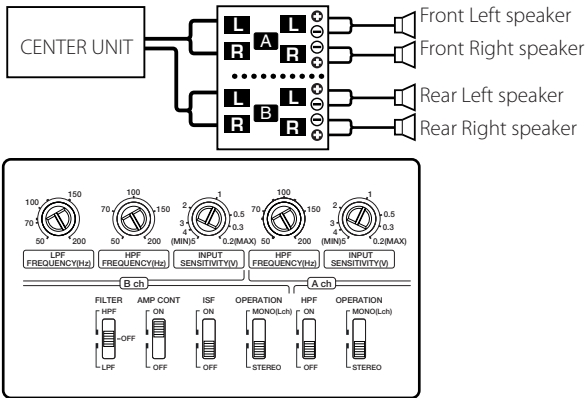

High-power 2-channel system

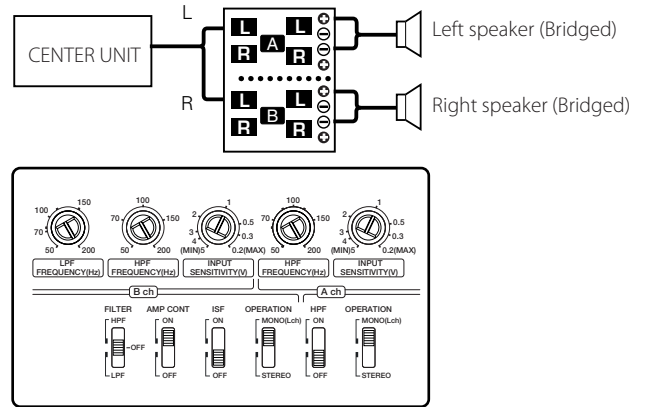

2-channel + Subwoofer system

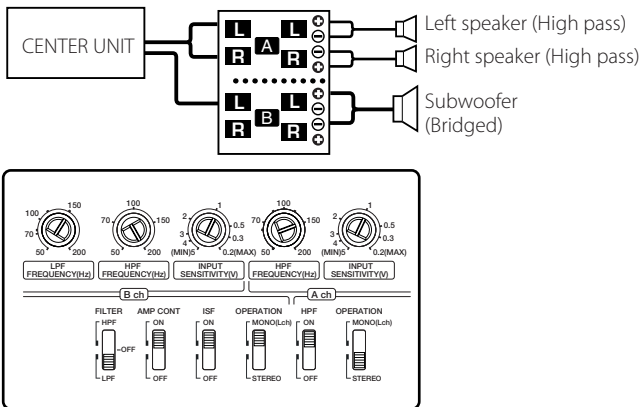

Tri-mode

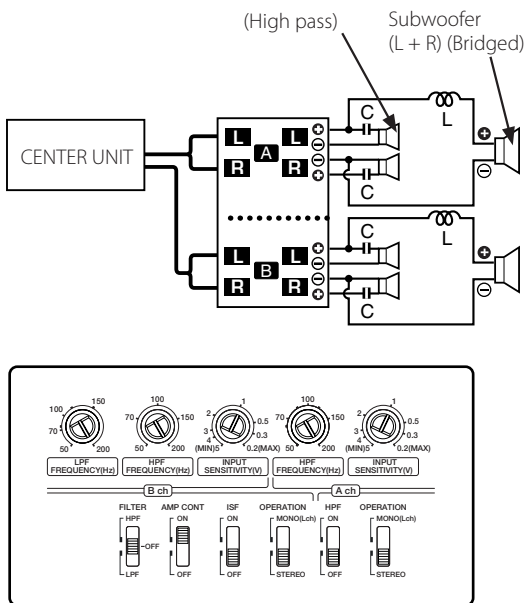

Principle of Tri-mode

Method of frequency band division using a coil and capacitor...in case of 6dB/oct. slope.

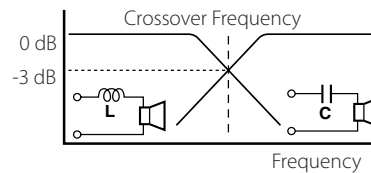

Coil (L):

Passes low frequencies and blocks high frequencies. (Low pass)

Capacitor (C):

Passes high frequencies and blocks low frequencies. (High pass)

$$L = \frac{159 \times R}{f_c} \text{ (mH)} \quad C = \frac{159000}{f_c \times R} \text{ (\mu F)} \quad f_c = \text{Cut of Frequency (Hz)} \quad R = \text{Speaker Impedance (\Omega)}$$

Example:

When it is required to set a crossover frequency of 120 Hz using speakers with an impedance of 4 ohms.

Prepare commercially-available coil and capacitor with the closest ratings to the results calculated from the formula above. The capacitor rating should be as close as possible to 331.25 (μF) and the coil rating should be as close as possible to 5.3 (mH).

CAUTION

- If you wish to bridge-connect a speaker, the speaker impedance must be no less than 4 ohms. Connecting a speaker with an impedance lower than 4 ohms may damage the unit.
- Be sure to connect capacitors to speakers to which high frequencies will be passed. Failure to do so will result in a drop of the combined impedance with the subwoofer.
- Ensure that the withstand voltage and current ratings of the capacitors (C) and coils (L) are sufficient.

Troubleshooting Guide

What might appear to be a malfunction in your unit may just be the result of slight misoperation or miswiring. Before calling service, first check the following table for possible problems.

| PROBLEM | POSSIBLE CAUSE | SOLUTION |
|--|--|--|
| No sound. (No sound from one side.) (Blown fuse.) | <ul style="list-style-type: none"> Input (or output) cables are disconnected. Protection circuit may be activated. Volume is too high. The speaker cord is shorted. | <ul style="list-style-type: none"> Connect the input (or output) cables. Check connections by referring to "Protection function". Replace the fuse and use lower volume. After check the speaker cord and fixing the cause of the short, replace the fuse. |
| The output level is too small (or too large). | <ul style="list-style-type: none"> The input sensitivity adjusting control is not set to the correct position. | <ul style="list-style-type: none"> Adjust the control correctly referring to "Controls". |
| The sound quality is bad. (The sound is distorted.) | <ul style="list-style-type: none"> The speakers wire are connected with wrong \oplus / \ominus polarity. A speaker wire is pinched by a screw in the car body. The switches may be set improperly. | <ul style="list-style-type: none"> Connect them properly checking the \oplus / \ominus of the terminals and wires well. Connect the speaker wire again so that it is not pinched by anything. Set switches properly by referring to "System examples". |
| The sound does not change even when you have changed it with the Amplifier Control. | <ul style="list-style-type: none"> The AMP CONT has been turned "OFF". The filtered band has been controlled by the Amplifier Control. | <ul style="list-style-type: none"> Turn the AMP CONT "ON". Turn the filter Off. |
| The set value cannot be changed by the Amplifier Control of the unit. | <ul style="list-style-type: none"> The AMP Control of the Center Unit is being used. | <ul style="list-style-type: none"> Release the AMP Control mode of the Center Unit. |
| The Amplifier Control cannot be operated from the Center Unit. | <ul style="list-style-type: none"> An incorrect ID number is used for the Master amplifier. The ID number of the amplifier has been changed. | <ul style="list-style-type: none"> Always set the ID number of the Master amplifier to "0". After you have changed the ID number of an amplifier, turn Off the POWER switch of the Center Unit first, then turn it On again. |

Specifications

Specifications subject to change without notice.

Audio Section..... KAC-X541

| | |
|--|----------------------------|
| RMS Power Output (+B = 14.4 V, CEA-2006) | |
| Normal (4 Ω /4ch) (1.0 % THD+N) | 88 W |
| (2 Ω /4ch) (1.0 % THD+N) | 124 W |
| Bridged (4 Ω /2ch) (1.0 % THD+N) | 270 W \times 2 |
| Dynamic Power (+B = 14.4 V, CEA-2006) | 100 W |
| Output Regulation (+B = 14.4 V, CEA-2006) | under 0.3 dB (4 Ω) |
| Signal to Noise Ratio (CEA-2006) | 76 dBA (W/4 Ω) |
| (Bypass) (CEA-2006) | 76 dBA (W/4 Ω) |
| Low Pass Filter Frequency (24 dB/oct.) (B channel) | 50 – 200 Hz (variable) |
| High Pass Filter Frequency (12 dB/oct.) | 50 – 200 Hz (variable) |
| Infrasonic Filter Frequency (24 dB/oct.) (B channel) | 15 Hz |
| Frequency Response (+0, -3 dB) | 5 Hz – 70 kHz |
| Sensitivity (rated output) (MAX.) | 0.2 V |
| (MIN.) | 5.0 V |
| Input Impedance | 10 k Ω |

Audio Section..... KAC-PS541

| | |
|--|------------------------|
| Max Power Output | 960 W |
| Rated Power Output (+B = 12.0 V) | |
| Normal (4 Ω) (20 Hz – 20 kHz, 0.05 % THD) | 45 W \times 4 |
| (2 Ω) (1 kHz, 0.5 % THD) | 90 W \times 4 |
| Bridged (4 Ω) (1 kHz, 0.5 % THD) | 180 W \times 2 |
| Rated Power Output (+B = 14.4 V) | |
| Normal (4 Ω) (20 Hz – 20 kHz, 0.05 % THD) | 60 W \times 4 |
| (4 Ω) (DIN : 45324 , +B = 14.4V) | 60 W \times 4 |
| (2 Ω) (1 kHz, 0.5 % THD) | 120 W \times 4 |
| Bridged (4 Ω) (1 kHz, 0.5 % THD) | 240 W \times 2 |
| Low Pass Filter Frequency (24 dB/oct.) (B channel) | 50 – 200 Hz (variable) |
| High Pass Filter Frequency (12 dB/oct.) | 50 – 200 Hz (variable) |
| Infrasonic Filter Frequency (24 dB/oct.) (B channel) | 15 Hz |
| Frequency Response (+0, -3 dB) | 5 Hz – 70 kHz |
| Signal to Noise Ratio | 105 dB |
| Sensitivity (rated output) (MAX.) | 0.2 V |
| (MIN.) | 5.0 V |
| Input Impedance | 10 k Ω |

Amplifier Control Section (EQ) (B channel) KAC-X541/PS541

| | |
|------------------|---------------------------|
| Bass frequency | 60 / 80 / 100 / 200 Hz |
| Bass level | -15 — +15 dB |
| Bass Q factor | 1.00 / 1.25 / 1.50 / 2.00 |
| Treble frequency | 10 / 12 / 15 / 17 kHz |
| Treble level | -15 — +15 dB |

General KAC-X541/PS541

| | |
|---|--|
| Operating Voltage | 14.4 V (11 – 16 V allowable) |
| Current Consumption (+B = 12.0 V, 1 kHz, 10 % THD, 4 Ω) | 42 A |
| Dimensions (W \times H \times D) | 446 \times 61 \times 259.5 mm 17-5/8 \times 2-3/8 \times 10-3/16 inch |
| Installation Size (W \times H \times D) | 446 \times 61 \times 265 mm 17-5/8 \times 2-3/8 \times 10-3/8 inch |
| Weight | 4.47 kg (9.85 lbs) |

KENWOOD