

KENWOOD

KRC-165

CASSETTE RECEIVER
INSTRUCTION MANUAL

KENWOOD CORPORATION

Contents

Before use

Safety precautions	2
--------------------------	---

General features

Power	4
Switching Modes	4
Volume	5
Attenuator	5
Loudness	5
Audio Control Setting	5
dB (Sound Coordinate)	6
Clock display	6
Adjusting Time	6

Tuner features

Tuning	7
Station Preset Memory	8
Auto Memory Entry	8
Frequency Step Setting	8
CRSC (Clean Reception System Circuit)	8

Cassette player features

Playing Cassette Tapes	9
Fast Forwarding and Rewinding Cassette Tapes	9
Tuner Call	10

Accessories

11

Installation Procedure

11

Connecting Wires to Terminals

12

Installation

13

Troubleshooting guide

15

Specifications

16

Safety precautions

⚠ WARNING

To prevent injury or fire, take the following precautions:

- Insert the unit all the way in until it is fully locked in place. Otherwise it may fall out of place when jolted.
- When extending the ignition, battery, or ground wires, make sure to use automotive-grade wires or other wires with a 0.75mm² (AWG18) or more to prevent wire deterioration and damage to the wire coating.
- To prevent a short circuit, never put or leave any metallic objects (such as coins or metal tools) inside the unit.
- If the unit starts to emit smoke or strange smells, turn off the power immediately and consult your Kenwood dealer.
- Be careful not to drop the unit or subject it to strong shock.
The unit may break or crack because it contains glass parts.
- Do not touch the liquid crystal fluid if the LCD is damaged or broken due to shock. The liquid crystal fluid may be dangerous to your health or even fatal.
If the liquid crystal fluid from the LCD contacts your body or clothing, wash it off with soap immediately.

CAUTION

To prevent damage to the machine, take the following precautions:

- Make sure to ground the unit to a negative 12V DC power supply.
- Do not open the top or bottom covers of the unit.
- Do not install the unit in a spot exposed to direct sunlight or excessive heat or humidity. Also avoid places with too much dust or the possibility of water splashing.
- Do not subject the faceplate to excessive shock, as it is a piece of precision equipment.
- When replacing a fuse, only use a new one with the prescribed rating. Using a fuse with the wrong rating may cause your unit to malfunction.
- To prevent a short circuit when replacing a fuse, first disconnect the wiring harness.
- Do not use your own screws. Use only the screws provided. If you use the wrong screws, you could damage the unit.

NOTE

- If you experience problems during installation, consult your Kenwood dealer.
- If the unit does not seem to be working right, try pressing the reset button first. If that does not solve the problem, consult your Kenwood dealer.

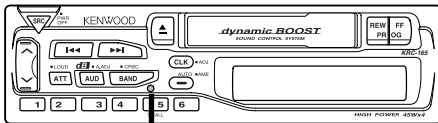

Reset button

- Characters in the LCD may become difficult to read in temperatures below 41 °F (5 °C).
- The illustrations of the display and the panel appearing in this manual are examples used to explain more clearly how the controls are used. Therefore, what appears on the display in the illustrations may differ from what appears on the display on the actual equipment, and some of the illustrations on the display may represent something impossible in actual operation.

Cleaning the Unit

If the faceplate of this unit is stained, wipe it with a dry soft cloth such as a silicon cloth. If the faceplate is stained badly, wipe the stain off with a cloth moistened with neutral cleaner, then wipe neutral detergent off.

CAUTION

Applying spray cleaner directly to the unit may affect its mechanical parts. Wiping the faceplate with a hard cloth or using a volatile liquid such as thinner or alcohol may scratch the surface or erase characters.

Cleaning the Tape Head

After you have listened to many cassettes over a long period of time, magnetic powder from the tapes and dust accumulates on the tape head, causing noise and a deterioration in sound quality. Clean the tape head using a cleaning tape or cleaning kit designed for use in car audio systems.

Handling Cassette Tapes

- Do not play a cassette whose tape has gone slack. In such a case, wind it tight using a pencil or the like in one of the spools. Playing slack cassette tapes can result in the tape tangling around the capstan and/or pinch rollers, causing trouble.
- Do not play a deformed cassette or one whose label is starting to come off, as it can cause the unit to malfunction.
- Do not leave tapes in hot places, such as on dashboards and other spots exposed to direct sunlight, or near heater outlets. They can deform the cassette.
- Avoid using extremely long cassette tapes, such as 100-minute-long tapes. Such tapes are very thin, and can tangle easily around the pinch rollers or other parts inside the unit, causing unit failure.
- Remove a cassette tape from the unit when not listening to it for a while. If you leave a tape in the unit too long, it may stick to the tape head and cause unit malfunction.

General features

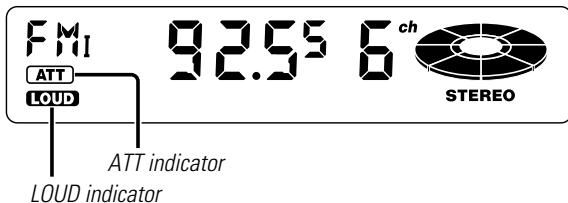
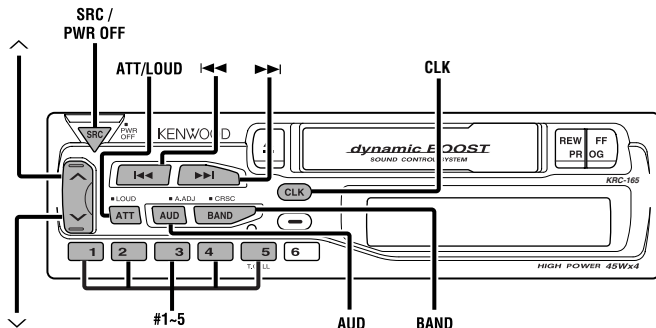

Power

Turning on the power:

Press the SRC (source) button.

NOTE

Turn the power on before carrying out the following procedures.

Turning off the power:

Press the PWR OFF button for at least one second.

Switching Modes

Switching Modes:

Each time you press the SRC (source) button, the mode switches as follows:

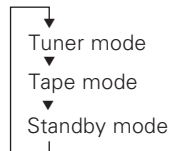

Selecting standby mode:

Press the SRC button repeatedly and switch to "OFF".

When "OFF" is displayed, the standby mode is activated.

The standby mode turns all functions off while leaving the power to the unit on. Use this mode when you want to have the display illuminated but don't want to listen to anything.

NOTE

The mode switches to the next mode from any mode which cannot be used.

Volume

Increasing Volume:

Press the \wedge button to turn up the volume.

Decreasing Volume:

Press the \vee button to turn down the volume.

Attenuator

This function allows you to turn down the volume quickly.

Turning Attenuator On/Off:

Press the ATT button to switch the attenuator on and off.

When the attenuator is on, the ATT indicator blinks.

When the attenuator is off, the volume returns to the original level.

NOTE

Turning the volume up, or turning it all the way down deactivates the attenuator function.

Loudness

This function amplifies low and high tones when the volume is turned down.

The LOUD indicator lights up when the loudness function is on.

Turning Loudness On/Off:

Press the LOUD button for at least one second to switch the loudness on and off.

Audio Control Setting

Adjust various parameters of sound quality.

1 Press the AUD button for at least one second to enter the control mode.

2 **Selecting mode**

Press either the BAND button.

Each time the button is pressed, the adjustment mode will change.

Please refer to the following for the contents of the adjustment modes.

NOTE Source tone memory

Each source (tape, FM and AM) has its own memory in which to store the bass and treble tone settings.

The settings made for a particular source are recalled automatically whenever you use that source (for example, FM mode uses the tone settings made for FM, AM for AM, etc.).

3 **Adjust each mode**

Press the $\lll\ggg$ button.

Please refer to the following for the adjusting values.

4 Press the AUD button to end the control mode.

"BAS": Adjust the bass level.

Setting values: - 8 - 8

"TRE": Adjust the treble level.

Setting values: - 8 - 8

"BL": Adjust the balance level.

Setting values: Left 15 - Right 15

General features

"FD": Adjust the fader level.

Setting values: Rear 15 - Front 15

dB (Sound Coordinate)

You can recall the best audio setting preset for different types of the music.

- 1 Press the AUD button to enter the Sound Coordinate mode.
- 2 Press a preset button (#1-5).
The preset settings of the bass and treble tones are recalled.
#1: Flat (dB-1)
#2: Rock (dB-2)
#3: Pops/Top 40 (dB-3)
#4: Jazz (dB-4)
#5: Easy (dB-5)
- 3 Press the AUD button to end the sound coordinate mode.

NOTE

You can call the following settings with this function; bass center frequency, bass level, bass quality factor, bass extension, treble center frequency, and treble level setting.

Clock display

Turning clock display On/Off:

Each time you press the CLK button, the display switches between the clock and each mode display.

Adjusting Time

Adjust the time.

- 1 When the time is not displayed, first press the CLK button to display the time.
- 2 Press the CLK button for at least two seconds to enter the clock adjustment mode. The time display will blink.
- 3
 - Adjusting the hours
Press the BAND button to advance the hours.
 - Adjusting the minutes
Press the ►| button to advance the minutes, or press the ◀◀ button to make the minutes go back.
- 4 Press the CLK button to end the clock adjustment mode.

Tuner features

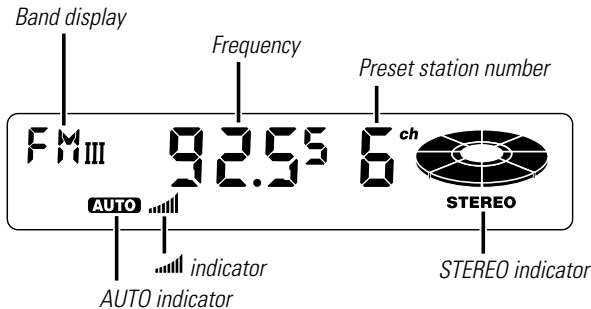
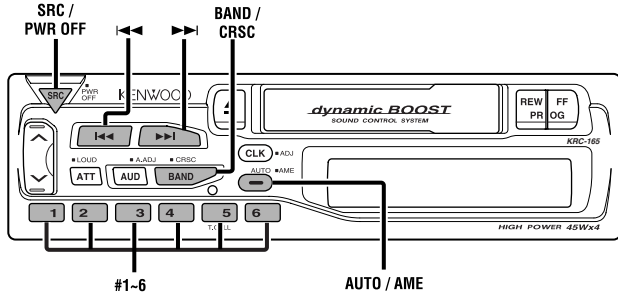

Tuning

You can choose between auto seek tuning of receivable frequencies and manual tuning.

- 1 Press the SRC (source) button repeatedly to select the tuner mode. "TUNE" is displayed when the tuner mode has been selected.
- 2 Press the BAND button to select the band. Each time you press the BAND button, the band switches between FM1, FM2, FM3, and AM.
- 3 Press the AUTO button to switch between auto seek tuning and manual tuning. The AUTO indicator lights up only when auto seek tuning is selected.
 - Auto Seek Tuning
 - Press the ►► button to seek higher frequencies.
 - Press the ◄◄ button to seek lower frequencies.
 - Manual Tuning
 - Press the ►► button to increase the frequency by one step.
 - Press the ◄◄ button to decrease the frequency by one step.

NOTE

The STEREO indicator lights up when stereo broadcasts are being received.

Tuner features

Station Preset Memory

Store the frequency of a station. You can then recall that station with a single touch of a button.

- 1 Select the band/ station that you want to have stored.
- 2 Press the button (#1-6) that you want to use for the station, for at least two seconds.
The button number blinks once in the display to indicate that the data has been stored.

Recalling a Preset Station:

Press the preset station button (#1-6) for the desired station. The number of the recalled station is displayed.

NOTE

You can store six stations in each of the FM1, FM2, FM3, and AM bands.

Auto Memory Entry

You can automatically store all the receivable frequencies in the band currently being listened to, and then recall them with the touch of a button later. This function is especially useful when you are travelling and do not know what stations are available. Up to six frequencies can be stored this way.

- 1 Select the band for auto memory entry.
- 2 Press the AME button for at least two seconds to start auto memory entry.
The numbers of the preset station buttons are shown in order. When all the stations in a certain band are stored in the preset memory, the auto memory entry stops. The tuner then plays the last station received.

Recalling a Preset Station:

Press the preset station button (#1-6) for the desired station. The number of the recalled station is displayed.

Frequency Step Setting

Switch the frequency step used in seeks. The factory defaults are 50 kHz for FM and 9 kHz for AM.

- 1 Turn the power off.
- 2 Hold down buttons #1 and #5, then turn the power back on.
The frequency step settings will be changed to 200 kHz for FM and 10 kHz for AM.

NOTE

When you change the frequency step settings, all memory contents will be erased.

Returning Frequency Step Settings to Original Values:

Repeat steps 1 and 2 above.

Clean (CRSC Reception System Circuit)

Temporarily have reception switched from stereo to mono to reduce multi-path noise when listening to the FM station. The factory default for this function is ON.

Turning CRSC On/Off:

Press the CRSC button for at least one second to turn the function on/off.

The  indicator lights up when CRSC is on.

NOTE

Strong electrical fields (such as from power lines) may cause unstable sound quality when CRSC is turned on. In such a situation, turn it off.

Cassette player features

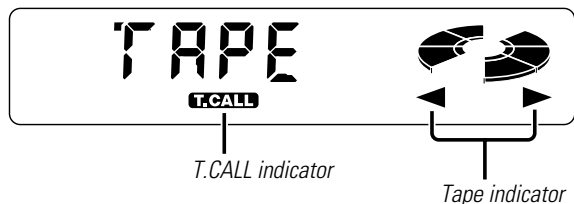
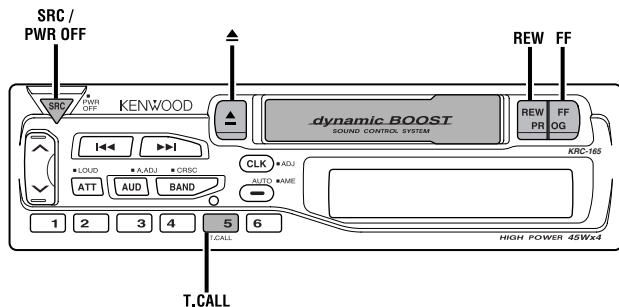

Playing Cassette Tapes

Loading and Playing Cassettes:

Load a cassette with the tape exposed on the right.

The tape starts playing automatically.

With side A facing up, the ► indicator lights up when side A is playing, and ◀ when side B is playing.

The ◀ ► indicator lights up while play is paused.

Playing Cassettes Already Loaded:

Press the SRC (source) button repeatedly to select the tape mode. "TAPE" is displayed when the tape mode has been selected.

Listening to the other side:

Press the FF button and REW button at the same time.

Tape play switches to the other side.

Stopping and Ejecting Cassettes:

Press the ▲ button.

The tape stops playing and the cassette ejects.

NOTE

Remove a cassette from the unit when not listening to it for a while. If you leave it in the unit too long, the tape may stick to the tape head and cause unit malfunction.

Fast Forwarding and Rewinding Cassette Tapes

Fast Forwarding Tapes:

Press the FF button.

The tape indicator blinks in the direction of the tape as it is being fast forwarded.

If the REW button is pressed, normal tape will begin.

Rewinding Tapes:

Press the REW button.

The tape indicator blinks in the direction of the tape as it is being rewound.

If the FF button is pressed, normal tape play will begin.

Cassette player features

Tuner Call

Switch automatically to the tuner while you are rewinding or fast forwarding the tape.

Turning Tuner Call On/Off:

Press the T.CALL button to switch tuner call on and off.

The T.CALL indicator lights up when tuner call is turned on.





NOTE

When you turn on the Tuner Call function, the motorised antenna will extend automatically.

Accessories

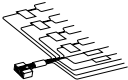
External view

Number of items

①	1
②	2
③	4
④	4

▲CAUTION

The use of any accessories except for those provided might result in damage to the unit. Make sure only to use the accessories shipped with the unit, as shown above.

Installation Procedure

1. To prevent a short circuit, remove the key from the ignition and disconnect the ⊖ battery.
2. Make the proper input and output wire connections for each unit.
3. Connect the speaker wires of the wiring harness.
4. Connect the wiring harness wires in the following order: ground, battery, ignition.
5. Connect the wiring harness connector to the unit.
6. Install the unit in your car.
7. Reconnect the ⊖ battery.
8. Press the reset button.

▲CAUTION

- If your car's ignition does not have an ACC position, connect the ignition wires to a power source that can be turned on and off with the ignition key. If you connect the ignition wire to a power source with a constant voltage supply, as with battery wires, the battery may die.
- If the console has a lid, make sure to install the unit so that the faceplate will not hit the lid when closing and opening.
- If the fuse blows, first make sure the wires aren't touching to cause a short circuit, then replace the old fuse with one with the same rating.
- Do not let unconnected wires or terminals touch metal on the car or anything else conducting electricity. To prevent a short circuit, do not remove the caps on the ends of the unconnected wires or the terminals.
- Connect the speaker wires correctly to the terminals to which they correspond. The unit may be damaged or fail to work if you share the ⊖ wires or ground them to any metal part in the car.
- After the unit is installed, check whether the brake lamps, blinkers, wipers, etc. on the car are working properly.
- Insulate unconnected wires with vinyl tape or other similar material.

Connecting Wires to Terminals

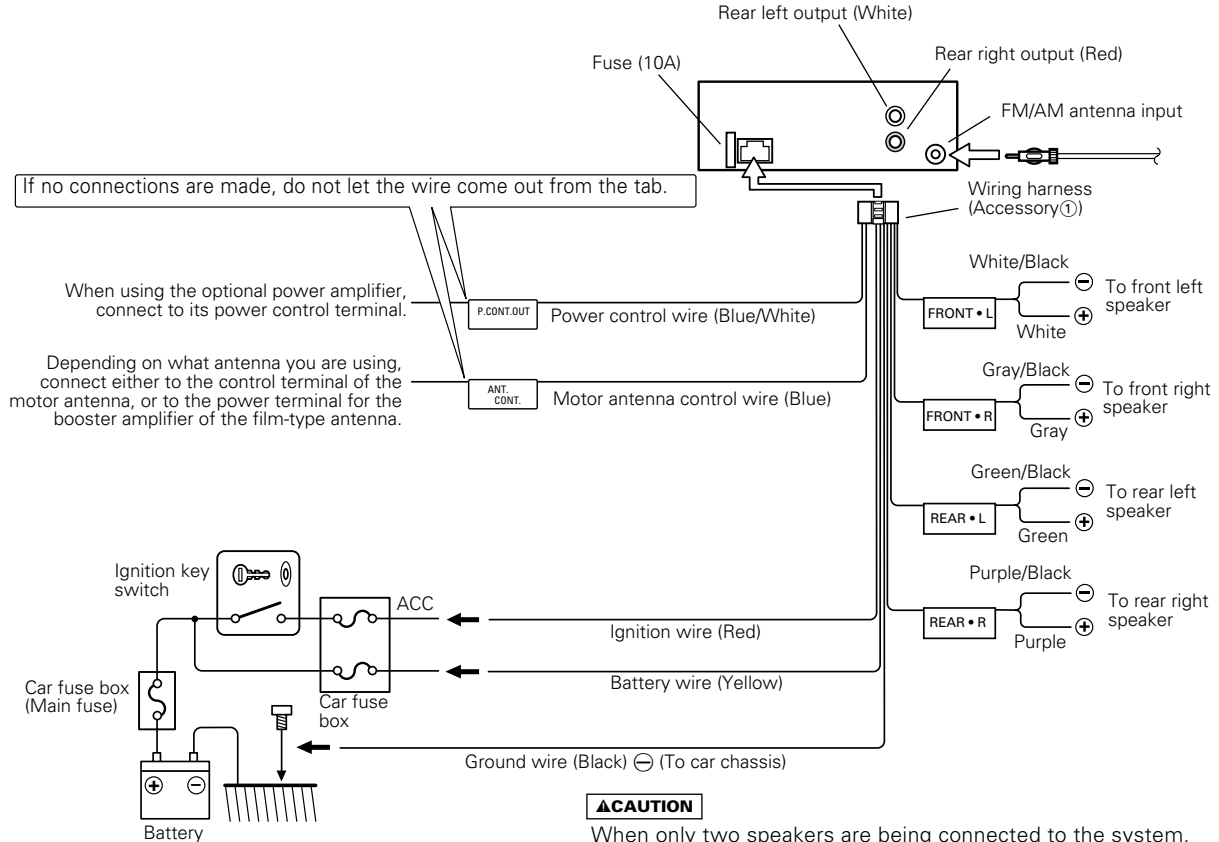

▲WARNING

If you connect the ignition wire (red) and the battery wire (yellow) to the car chassis (ground), you may cause a short circuit, that in turn may start a fire. Always connect those wires to the power source running through the fuse box.

▲CAUTION

When only two speakers are being connected to the system, connect the connectors either to both the front output terminals or to both the rear output terminals (do not mix front and rear). For example, if you connect the ⊕ connector of the left speaker to a front output terminal, do not connect the ⊖ connector to a rear output terminal.

Installation

■ Installation

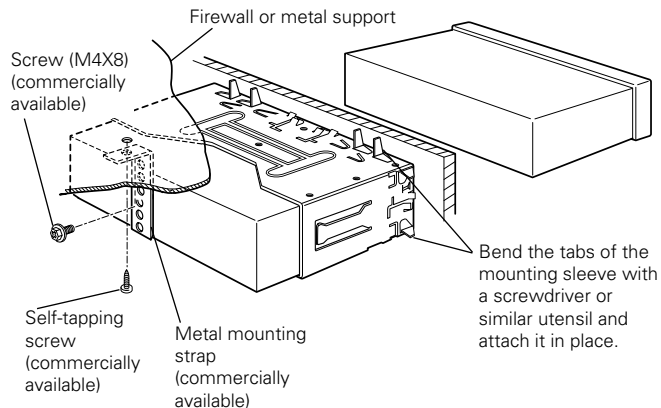

NOTE

Make sure that the unit is installed securely in place. If the unit is unstable, it may malfunction (for example, the sound may skip).

■ Installing in Japanese-Made Cars

- 1 Refer to the section “Removing the hard rubber frame (P. 14)” and then remove the hard rubber frame.
- 2 Align the holes in the unit (two locations on each side) with the vehicle mounting bracket and secure the unit with the accessory screws.

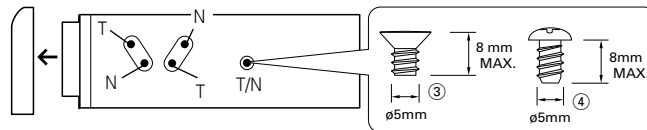

CAUTION

- During installation, do not use any screws except for those provided. The use of different screws might result in damage to the main unit.
- Damage may occur if a screwdriver or similar tool is used with excessive force during the installations.

Installation

■ Removing the hard rubber frame

- 1 Engage the catch pins on the removal tool and remove the two locks on the lower level.
Lower the frame and pull it forward as shown in the figure.

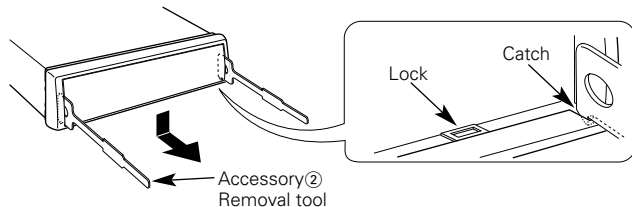

- 2 When the lower level is removed, remove the upper two locations.

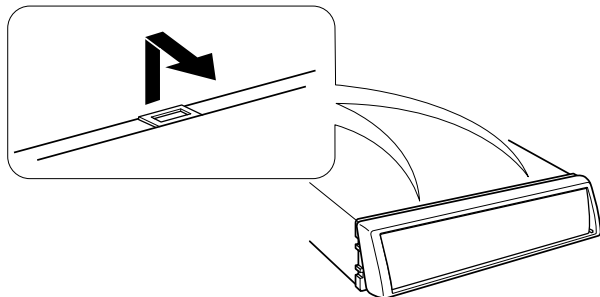

NOTE

The frame can be removed from the top side in the same manner.

■ Removing the Unit

- 1 Refer to the section “Removing the hard rubber frame” and then remove the hard rubber frame.
- 2 Remove the Hex-head screw with integral washer (M4×8) on the back panel.
- 3 Insert the two removal tools deeply into the slots on each side, as shown.

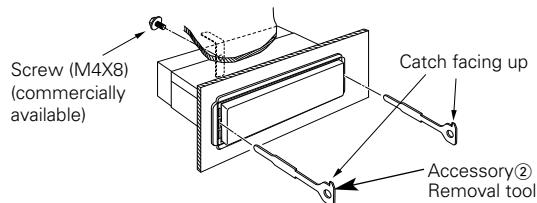

- 4 Lower the removal tool toward the bottom, and pull out the unit halfway whilst pressing towards the inside.

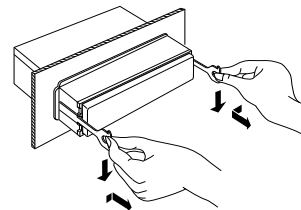

CAUTION

Be careful to avoid injury from the catch pins on the removal tool.

- 5 Pull the unit all the way out with your hands, being careful not to drop it.

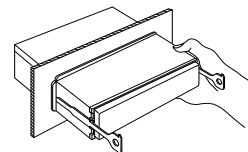

Troubleshooting Guide

What might seem to be a malfunction in your unit may just be the result of slight misoperation or miswiring. Before calling service, first check the following table for possible problems.

PROBLEM	POSSIBLE CAUSE	SOLUTION
The power does not turn on.	The fuse has blown.	After checking for short circuits in the wires, replace the fuse with one with the same rating.
No sound can be heard, or the volume is low.	Attenuator is turned on.	Turn off Attenuator.
	The fader or balance settings are set all the way to one side.	Reset the fader or balance settings.
	The input/output wires or wiring harness are connected incorrectly.	Reconnect the input/output wires or the wiring harness correctly. See the section on "Connecting Wires to Terminals".
Tape has been inserted but there is no sound/the unit will not go into tape mode	The cassette tape is bad.	Try playing another cassette tape. If works fine, the first tape was bad.
	The tape has not been inserted correctly in the unit.	Re-insert the tape.
Nothing happens when the buttons are pressed.	The computer chip in the unit is not functioning normally.	Press the reset button on the unit (see p. 3).
The sound quality is poor or distorted.	The tape head is dirty.	Clean the tape head, referring to the section on "Cleaning the tape head" (see p. 3).
	One of the speaker wires is being pinched by a screw in the car.	Check the speaker wiring.
	The speakers are not wired correctly.	Reconnect the speaker wires so that each output terminal is connected to a different speaker.
Radio reception is poor.	The car antenna is not extended.	Pull the antenna out all the way.
	The antenna control wire is not connected.	Connect the wire correctly, referring to the section on "Connecting Wires to Terminals".
The memory is erased when the ignition is turned off.	The battery wire has not been connected to the proper terminal.	Connect the wire correctly, referring to the section on "Connecting Wires to Terminals".
	The ignition and battery wire are incorrectly connected.	Connect the wire correctly, referring to the section on "Connecting Wires to Terminals".

Specifications

English

Specifications subject to change without notice.

FM tuner section

Frequency Range	
(50kHz)	87.5MHz - 108.0MHz
(200kHz)	87.9MHz - 107.9MHz
Usable Sensitivity (S/N: 30dB).....	9.3dBf (0.8 μ V/75 Ω)
Quieting Sensitivity (S/N: 50dB)	15.2dBf (1.6 μ V/75 Ω)
Frequency Response (\pm 3.0dB).....	30Hz-15kHz
Signal to Noise ratio	70dB(MONO)
Selectivity	\geq 80 dB(\pm 400 kHz)
Stereo Separation	40dB(1kHz)

AM tuner section

Frequency Range	
(9kHz)	531kHz - 1611kHz
(10kHz)	530kHz - 1700kHz
Usable Sensitivity (S/N: 20dB)28 dB μ (25 μ V)

Cassette player section

Tape Speed	4.76 cm/sec.
Wow & Flutter.....	0.12 % (WRMS)
Frequency response (\pm 3 dB).....	30 Hz -14 kHz (120 μ s)
Separation	40 dB (1 kHz)
Signal to Noise ratio	52 dB

Audio section

Maximum output power	45 W x 4
Full Bandwidth Power (at less than 1% THD)	22 W x 4
Tone action	
Bass	100 Hz \pm 10 dB
Treble	10 kHz \pm 10 dB
Preout level / load.....	1800 mV / 10 k Ω
Preout Impedance.....	\leq 600 Ω

General

Operating voltage (11 - 16V allowable).....	14.4 V
Current Consumption	10 A
Installation Size (W x H x D)	182 x 53 x 158 mm
Weight	1.3 kg